

# System 300S

CP | 343-1EX71 | Manual

HB140 | CP | 343-1EX71 | en | 26-10

SPEED7 CP 343S-NET



YASKAWA Europe GmbH  
Philipp-Reis-Str. 6  
65795 Hattersheim  
Germany  
Tel.: +49 6196 569-300  
Fax: +49 6196 569-398  
Email: [info@yaskawa.eu](mailto:info@yaskawa.eu)  
Internet: [www.yaskawa.eu.com](http://www.yaskawa.eu.com)

## Table of contents

<b>1</b>	<b>General</b> .....	<b>4</b>
1.1	About this manual .....	4
1.2	Copyright © YASKAWA Europe GmbH .....	5
1.3	Safety instructions .....	6
<b>2</b>	<b>Basics</b> .....	<b>9</b>
2.1	Safety notes for the user .....	9
2.2	Hints for the project engineering .....	10
2.3	General data .....	12
2.3.1	Use in difficult operating conditions .....	13
<b>3</b>	<b>Assembly and installation guidelines</b> .....	<b>14</b>
3.1	Overview .....	14
3.2	Installation dimensions .....	15
3.3	Assembly SPEED-Bus .....	16
3.4	Industrial security and installation guidelines .....	19
3.4.1	Industrial security in information technology .....	19
3.4.2	Installation guidelines .....	21
<b>4</b>	<b>Hardware description</b> .....	<b>24</b>
4.1	Properties .....	24
4.2	Structure .....	25
4.3	Technical data .....	27
<b>5</b>	<b>Deployment</b> .....	<b>29</b>
5.1	Basics - Industrial Ethernet in automation .....	29
5.2	Basics - ISO/OSI reference model .....	30
5.3	Basics - Terms .....	31
5.4	Basics - Protocols .....	32
5.5	Basics - IP address and subnet .....	34
5.6	Basics - MAC address and TSAP .....	36
5.7	Fast introduction .....	36
5.8	Addressing at SPEED-Bus .....	40
5.9	Hardware configuration .....	40
5.9.1	Fast introduction .....	41
5.9.2	Requirements .....	41
5.9.3	Steps of project engineering .....	42
5.10	Configure connections .....	46
5.10.1	Overview .....	46
5.10.2	Siemens NetPro .....	48
5.10.3	Connection type - S7 .....	51
5.10.4	Connection type - Send/Receive .....	53
5.11	NCM diagnostic - Help for error diagnostic .....	60
5.12	Coupling to other systems .....	62

About this manual

# 1 General

## 1.1 About this manual

### Objective and contents

This manual describes the CP 343-1EX71 of the System 300S from Yaskawa.

- It describes the structure, configuration and application.
- The manual is targeted at users with good basic knowledge in automation technology.
- The manual does not replace sufficient basic knowledge of automation technology or sufficient familiarity with the specific product.
- The manual consists of chapters. Each chapter describes a completed topic.
- For guidance, the manual provides:
  - An overall table of contents at the beginning of the manual
  - References with pages numbers

### Validity of the documentation

Product	Order number	as of version:	
CP 343S-NET	343-1EX71	CP-HW: 02	CP-FW: V2.1.7

### Documentation

In the context of the use of the pertinent Yaskawa product, the manual is to be made accessible to the pertinent qualified personnel in:

- Project engineering
- Installation department
- Commissioning
- Operation

### Icons and headings

Important passages in the text are highlighted by following icons and headings:



#### **DANGER**

Immediate or likely danger. Personal injury is possible.



#### **CAUTION**

Damages to property is likely if these warnings are not heeded.



*Supplementary information and useful tips.*

## 1.2 Copyright © YASKAWA Europe GmbH

### All rights reserved

This document contains protected information of Yaskawa and may not be disclosed or used outside of an agreement made in advance with Yaskawa and only in accordance with that agreement.

This document is protected by copyright laws. Reproduction, distribution, or modification of this document or excerpts thereof is not permitted without the written consent of Yaskawa and the owner of this document, except in accordance with applicable agreements, contracts or licenses.

For permission to reproduce or distribute, please contact: YASKAWA Europe GmbH, European Headquarters, Philipp-Reis-Str. 6, 65795 Hattersheim, Germany

Tel.: +49 6196 569 300

Fax.: +49 6196 569 398

E-mail: [info@yaskawa.eu](mailto:info@yaskawa.eu)

Internet: [www.yaskawa.eu.com](http://www.yaskawa.eu.com)

### Download Center

By entering the product order number in the '*Download Center*' at [www.yaskawa.eu.com](http://www.yaskawa.eu.com), the pertinent manuals, data sheets, declarations of conformity, certificates and other helpful information for your product can be found.

### Trademarks

VIPA, SLIO, System 300S and SPEED7 are registered trademarks of YASKAWA Europe GmbH.

SIMATIC, STEP, TIA Portal, S7-300 and S7-400 are registered trademarks of Siemens AG.

All Microsoft Windows, Office and Server products mentioned are registered trademarks of Microsoft Inc., USA.

All other trademarks, logos and service or product marks specified herein are owned by their respective companies.

### General terms of use

Every effort was made by Yaskawa to ensure that the information contained in this document was complete and correct at the time of publication. Nevertheless, the information contained therein is only owed by Yaskawa as it is available at Yaskawa. Correctness is not assured by Yaskawa, the right to change the information contained herein is always reserved by Yaskawa. There is no obligation to inform the customer of any changes.

The customer is requested to actively keep this documentation up to date. The use of the products covered by these instructions, together with the associated documentation, is always at the customer's own risk, in accordance with the applicable guidelines and standards. This documentation describes the hardware and software components and functions of the product. It is possible that units are described which the customer does not have. The exact scope of delivery is described in the respective purchase contract.

### Terminology '*Master*' and '*Slave*' as technical terms

The terms '*Master*' and '*Slave*' were established in many technical areas decades ago and are used in a clearly defined way, which is independent of their historical meaning.

In this manual, the terms '*Master*' and '*Slave*' are used in a purely functional and non-judgemental way. These terms are well established in numerous international regulations, standards and documentations. Switching to alternative terms could lead to misunderstandings and ambiguities in application.

We continue to use the terms '*Master*' and '*Slave*', but are aware of their origins and are committed to reflective, non-discriminatory communication.

## Safety instructions

**Document support**

Contact your local representative of YASKAWA Europe GmbH if you have errors or questions regarding the content of this document. You can reach YASKAWA Europe GmbH via the following contact:

Email: Documentation.HER@yaskawa.eu

**Technical support**

Contact your local representative of YASKAWA Europe GmbH if you encounter problems or have questions regarding the product. If such a location is not available, you can reach the Yaskawa customer service via the following contact:

YASKAWA Europe GmbH,  
European Headquarters, Philipp-Reis-Str. 6, 65795 Hattersheim, Germany  
Tel.: +49 6196 569 500 (hotline)  
Email: support@yaskawa.eu

## 1.3 Safety instructions

**General safety instructions****DANGER****Danger to life due to non-compliance with safety instructions**

Non-compliance with the safety instructions in the manual can result in serious injury or death. The manufacturer is not responsible for any injuries or damage to the equipment.

**CAUTION****Before commissioning and operating the components described in this manual, it is essential to note the following:**

- Modifications to the automation system must only be done in a voltage-free state!
- Connection and modification only by trained electricians
- National regulations and guidelines in the respective country of use must be observed and complied with (installation, protective measures, EMC, etc.)

**Intended use**

- It is the customer's responsibility to comply with all pertinent standards, codes, or regulations applicable to the use of the product, including those that apply when the Yaskawa product is used in combination with other products.
- The customer must confirm that the Yaskawa product is suitable for the customer's plant, machinery and equipment.
- If the Yaskawa product is used in a manner not specified by this manual, the protection provided by the Yaskawa product may be impaired and the use may result in material or immaterial damage.
- Contact Yaskawa to determine whether use is permitted in the following applications. If the use in the respective application is permissible, the Yaskawa product is to be used by considering additional risk assessments and specifications, and safety measures are to be provided to minimise the dangers in the event of a fault. Special caution is required and protective measures must be taken in the case of:
  - Outdoor use, use with possible chemical contamination or electrical interference, or use under conditions or in environments which are not described in product catalogs or manuals.
  - Nuclear control systems, combustion systems, railway systems, aviation systems, automotive systems, medical devices, amusement machines and equipment that is specifically regulated by industry or government.
  - Systems, machines and devices that can pose a risk to life or property.
  - Systems that require a high degree of reliability, such as gas, water or electricity supply systems or systems that operate 24 hours a day.
  - Other systems that require a similarly high level of security.
- Never use the Yaskawa product in an application where failure of the product could cause serious danger to life, limb, health or property without first ensuring that the system is designed to provide the required level of safety with risk warnings and redundancy to avoid the realisation of such dangers and that the Yaskawa product is properly designed and installed.
- The connection examples and other application examples described in the product catalogs and manuals of Yaskawa are for reference purposes. Check the functionality and safety of the devices and systems actually to be used before using the Yaskawa product.
- To avoid accidental harm to third parties, read and understand all prohibitions on use and precautions, and operate the Yaskawa product correctly.

**Field of application**

- The Yaskawa product is not suited for use in life-support machines or systems.
- Please contact your Yaskawa representative or Yaskawa distributor if considering the use of the Yaskawa product for special purposes, such as machines or systems used in passenger cars, in medical, aircraft and aerospace applications, for power supply of networks, for electrical power distribution or for underwater applications.

**DANGER**

The device is not permitted for use

- in explosive environments (EX zone)

The system is designed and manufactured for proper use and use in accordance with the user manual and is designed for:

- Communication and process control
- general control and automation tasks
- for industrial use
- operation within the environmental conditions specified in the technical data
- installation in a cabinet

**DANGER**

**If this Yaskawa product is used in applications where failure of the device can result in the loss of human life, a serious accident or physical injury, you must install appropriate safety devices.**

- Death or serious injury can result if you do not install the safety devices properly.

**Disclaimer**

(1) The contractual and legal liability of Yaskawa and the legal representatives and vicarious agents of Yaskawa for compensation and reimbursement of expenses in relation to the content of this documentation is excluded or limited as follows:

a) For slightly negligent breaches of *Essential Contractual Duties* arising from the contractual obligation, for Yaskawa the amount of liability is limited to the foreseeable damage typical for the contract. '*Essential Contractual Duties*' are those duties that characterise the performance of the contract and on which the Yaskawa customer may reasonably rely.

(b) In each case, Yaskawa is not liable for (i) the slightly negligent breach of duties arising from the duties that are not *Essential Contractual Duties*, as well as (ii) force majeure, i.e. external events that have no operational connection and cannot be averted even by exercising the utmost care that can reasonably be expected.

(2) The aforementioned limitation of liability does not apply (i) in cases of mandatory statutory liability (in particular under the product liability law), (ii) if and to the extent that Yaskawa has assumed a guarantee or same as guaranteed procurement risk according to § 276 BGB, (iii) for culpably caused injuries to life, limb and/or health, also by representatives or vicarious agents, as well as (iv) in case of delay in the event of a fixed completion date.

(3) A reversal of the burden of proof is not associated with the provisions above.

**Disposal**

**National rules and regulations apply to the disposal of the unit!**

## 2 Basics

### 2.1 Safety notes for the user

#### Handling of electrostatic sensitive modules

The modules make use of highly integrated components in MOS-Technology. These components are extremely sensitive to over-voltages that can occur during electrostatic discharges. The following symbol is attached to modules that can be destroyed by electrostatic discharges.



The Symbol is located on the module, the module rack or on packing material and it indicates the presence of electrostatic sensitive equipment. It is possible that electrostatic sensitive equipment is destroyed by energies and voltages that are far less than the human threshold of perception. These voltages can occur where persons do not discharge themselves before handling electrostatic sensitive modules and they can damage components thereby, causing the module to become inoperable or unusable. Modules that have been damaged by electrostatic discharges can fail after a temperature change, mechanical shock or changes in the electrical load. Only the consequent implementation of protection devices and meticulous attention to the applicable rules and regulations for handling the respective equipment can prevent failures of electrostatic sensitive modules.

#### Shipping of modules

Modules must be shipped in the original packing material.

#### Measurements and alterations on electrostatic sensitive modules

When you are conducting measurements on electrostatic sensitive modules you should take the following precautions:

- Floating instruments must be discharged before use.
- Instruments must be grounded.

Modifying electrostatic sensitive modules you should only use soldering irons with grounded tips.



#### CAUTION

Personnel and instruments should be grounded when working on electrostatic sensitive modules.

## 2.2 Hints for the project engineering

### Overview

For the project engineering of a SPEED7 system please follow this approach:

- Project engineering of the SPEED7-CPU and the internal DP master (if existing)
- Project engineering of the real plugged modules at the standard bus
- Project engineering of the internal Ethernet PG/OP channel after the real plugged modules as virtual CP 343-1 (Setting of IP address, subnet mask and gateway for online project engineering)
- Project engineering of an internal CP343 (if existing) as 2. CP 343-1
- Project engineering and connection of the SPEED-Bus-CPs res. -DP master as CP 343-1 (343-1EX11) res. CP 342-5 (342-5DA02 V5.0)
- Project engineering of all SPEED-Bus modules as single DP slaves in a virtual DP master module (SPEEDBUS.GSD required)



*Please do always use the corresponding CPU from Siemens in the hardware catalog to configure a CPU 31xS from Yaskawa. For the project engineering, a thorough knowledge of the SIMATIC manager and the hardware configurator from Siemens is required!*

### Requirements

The hardware configurator is part of the Siemens SIMATIC manager. It serves the project engineering. Please look at the hardware catalog for the modules that may be configured. For the deployment of the System 300S modules at the SPEED-Bus the inclusion of the System 300S modules into the hardware catalog via the GSD-file SPEEDBUS.GSD is necessary.

### Approach

The project engineering of the SPEED7-CPU has the following components: To be compatible with the Siemens SIMATIC manager, the following steps are required:

#### Standard bus

Slot	Module
1	
2	<b>CPU ...</b>
X...	...
X...	...
3	

real modules at the standard bus

343-1EX11 (PG/OP)

343-1EX11 (only CPU 31xSN)

CPs res. DP master at the SPEED-Bus as 343-1EX11 res. 342-5DA02

342-5DA02 V5.0

virtual DP master for CPU and all SPEED-Bus modules

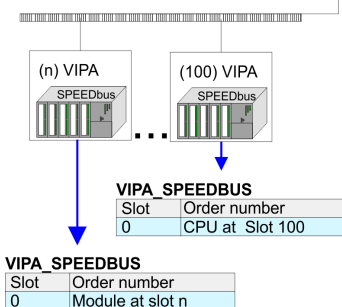

#### 1. Preparation

Start the hardware configurator from Siemens and include the SPEEDBUS.GSD for the SPEED-Bus.

#### 2. Project engineering of the CPU

Project the corresponding CPU. If your SPEED7-CPU contains a DP master, you may now connect it with PROFIBUS and configure your DP slaves.

#### 3. Project engineering of the real plugged modules at the standard bus

Set the modules that are at the right side of the CPU at the standard bus starting with slot 4.

#### 4. Project engineering of the integrated CPs

For the internal Ethernet PG/OP channel you have to set a CP 343-1 (343-1EX11) as 1. module at the real plugged modules. If your SPEED7-CPU has additionally an integrated CP 343, this is also configured as CP 343-1 but always below the former placed CP 343-1.

#### 5. Project engineering of the SPEED-Bus-CPs and -DP master

Plug and connect all CPs as 343-1EX11 and DP master as 342-5DA02 V5.0 at the SPEED-Bus below the former configured internal CPU components.



*Please regard that the sequence within a function group (CP res. DP master) corresponds the sequence at the SPEED-Bus from right to left.*

**6.** Project engineering of the CPU and all SPEED-Bus modules in a virtual master system

The slot assignment of the SPEED-Bus modules and the parameterization of the in-/output periphery happens via a virtual PROFIBUS DP master system. For this, place a DP master (342-5DA02 V5.0) with master system as last module. The PROFIBUS address must be < 100! Now include the slave "VIPA\_SPEEDBUS" for the CPU and every module at the SPEED-Bus. After the installation of the SPEEDBUS.GSD you may find this under *Profibus-DP / Additional field devices / I/O / VIPA\_SPEEDBUS*. Set the slot number of the module (100...110) as PROFIBUS address and plug the according module at slot 0 of the slave system.

**Bus extension with IM 360 and IM 361**

To extend the bus you may use the IM 360 from Siemens, where 3 further extensions racks can be connected via the IM 361. Bus extensions must be placed at slot 3. More detailed information is to be found in the chapter "Deployment CPU 31xS" at "Addressing".

**Summary**

The following illustration summarizes all project engineering steps:

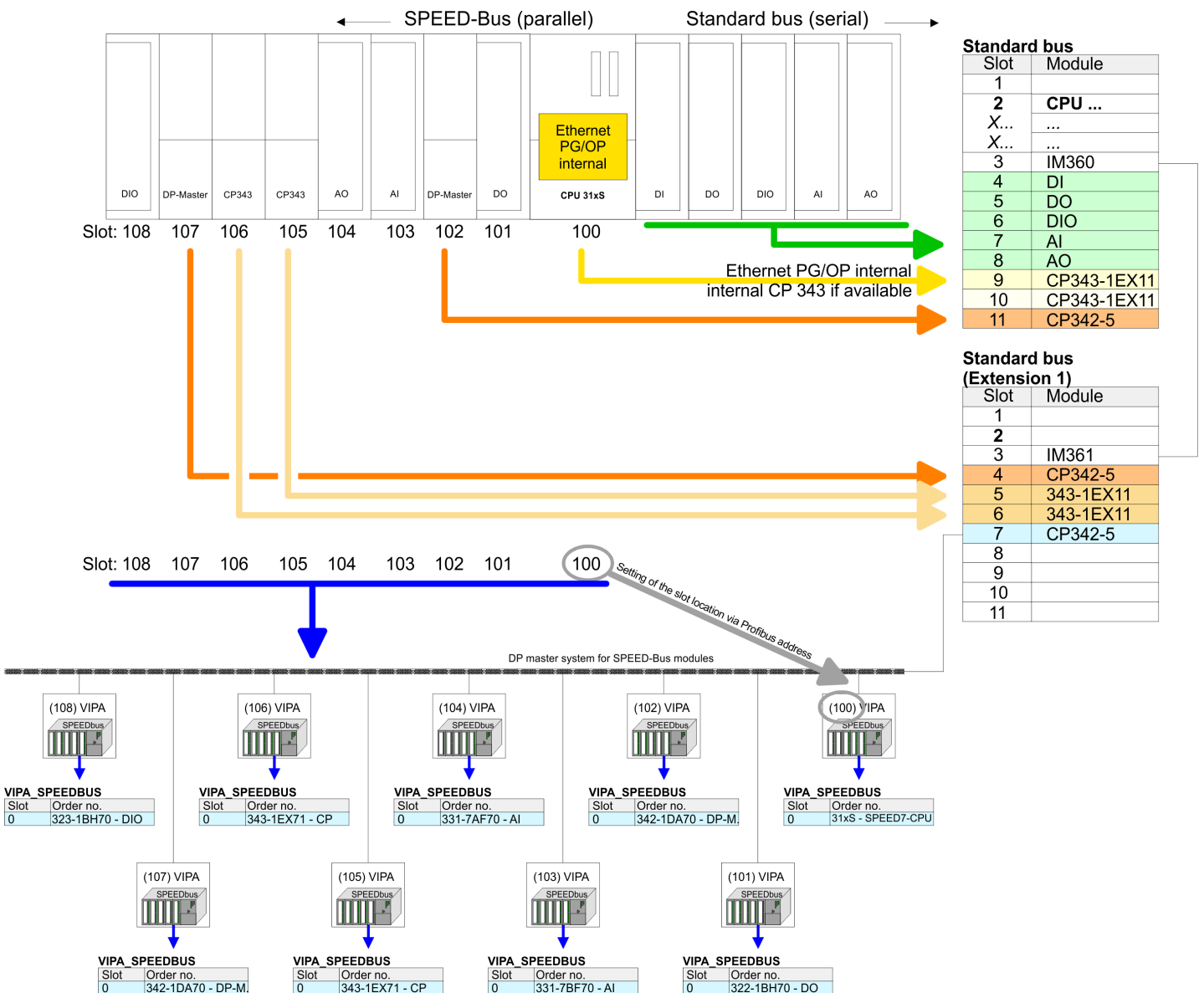

The according module is to be taken over from the HW catalog of VIPA\_SPEEDBUS on slot 0.

## General data



The sequence of the DPM and CP function groups is insignificant. You only have to take care to regard the sequence within a function group (DP1, DP2... res. CP1, CP2 ...).

**Hint, valid for all SPEED-Bus modules!**

The SPEED-Bus always requires the Siemens DP master CP 342-5 (342-5DA02 V5.0) as last module to be included, connected and parameterized to the operation mode DP master. Every SPEED-Bus module has to be connected as VIPA\_SPEED-Bus slave into this master system. By setting the SPEED-Bus slot number via the PROFIBUS address and by including the according SPEED-Bus module at slot 0, the SIMATIC manager receives information about the modules at the SPEED-Bus.

## 2.3 General data

**Conformity and approval**

## Conformity

CE	2014/35/EU	Low-voltage directive
	2014/30/EU	EMC directive
Approval		
UL		Refer to Technical data
others		
RoHS	2011/65/EU	Restriction of the use of certain hazardous substances in electrical and electronic equipment

**Protection of persons and device protection**

Type of protection	-	IP20
Electrical isolation		
to the field bus	-	electrically isolated
to the process level	-	electrically isolated
Insulation resistance		-
Insulation voltage to reference earth		
Inputs / outputs	-	AC / DC 50V, test voltage AC 500V
Protective measures	-	against short circuit

**Environmental conditions to EN 61131-2**

## Climatic

Storage / transport	EN 60068-2-14	-25...+70°C
Operation		
Horizontal installation hanging	EN 61131-2	0...+60°C
Horizontal installation lying	EN 61131-2	0...+55°C
Vertical installation	EN 61131-2	0...+50°C
Air humidity	EN 60068-2-30	RH1 (without condensation, rel. humidity 10...95%)
Pollution	EN 61131-2	Degree of pollution 2
Installation altitude max.	-	2000m
Mechanical		
Oscillation	EN 60068-2-6	1g, 9Hz ... 150Hz
Shock	EN 60068-2-27	15g, 11ms

**Mounting conditions**

Mounting place	-	In the control cabinet
Mounting position	-	Horizontal and vertical

EMC	Standard	Comment	
Emitted interference	EN 61000-6-4	Class A (Industrial area)	
Noise immunity zone B	EN 61000-6-2	Industrial area	
		EN 61000-4-2	ESD 8kV at air discharge (degree of severity 3), 4kV at contact discharge (degree of severity 2)
		EN 61000-4-3	HF field immunity (casing) 80MHz ... 1000MHz, 10V/m, 80% AM (1kHz) 1.4GHz ... 2.0GHz, 3V/m, 80% AM (1kHz) 2GHz ... 2.7GHz, 1V/m, 80% AM (1kHz)
		EN 61000-4-6	HF conducted 150kHz ... 80MHz, 10V, 80% AM (1kHz)
		EN 61000-4-4	Burst
	EN 61000-4-5	Surge <sup>1</sup>	

1) Due to the high-energetic single pulses with Surge an appropriate external protective circuit with lightning protection elements like conductors for lightning and overvoltage is necessary.

### 2.3.1 Use in difficult operating conditions



**Without additional protective measures, the products must not be used in locations with difficult operating conditions; e.g. due to:**

- dust generation
- chemically active substances (corrosive vapors or gases)
- strong electric or magnetic fields

### 3 Assembly and installation guidelines

#### 3.1 Overview

##### SPEED-Bus

- The SPEED-Bus is a 32bit parallel bus developed from Yaskawa.
- Via the SPEED-Bus you may connect up to 10 SPEED-Bus modules to your CPU.
- In opposite to the "standard" backplane bus where the modules are plugged-in at the right side of the CPU by means of single bus connectors, the modules at the SPEED-Bus are plugged-in at the left side of the CPU via a special SPEED-Bus rail.
- Yaskawa delivers profile rails with integrated SPEED-Bus for 2, 6, or 10 SPEED-Bus peripheral modules with different lengths.
- Each SPEED-Bus rail has a slot for an external power supply. This allows you to raise the maximum current at the back plane bus. Only the "SLOT1 DCDC" allows you to plug-in either a SPEED-Bus module or an additional power supply (307-1FB70).

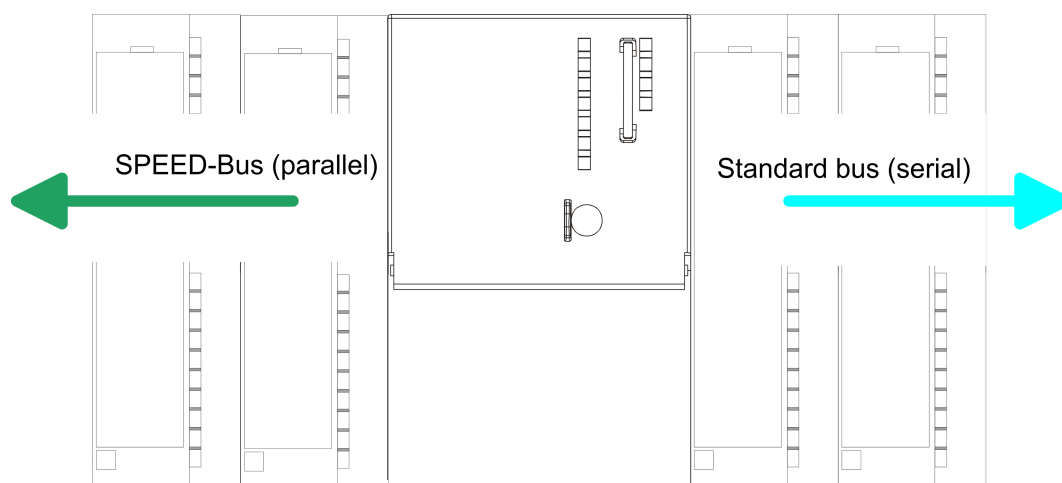

##### SPEED-Bus peripheral modules

The SPEED-Bus peripheral modules may exclusively be plugged into the SPEED-Bus slots at the left side of the CPU. The following SPEED-Bus modules are in preparation:

- Fast fieldbus modules like PROFIBUS DP, Interbus, CANopen master and CANopen slave
- Fast CP 343 (CP 343 Communication processor for Ethernet)
- Fast CP 341 with double RS 422/485 interface
- Fast digital input/output modules (Fast Digital IN/OUT)

##### Serial Standard bus

The single modules are directly installed on a profile rail and connected via the backplane bus coupler. Before installing the modules you have to clip the backplane bus coupler to the module from the backside. The backplane bus couplers are included in the delivery of the peripheral modules.

##### Parallel SPEED-Bus

With SPEED-Bus the bus connection happens via a SPEED-Bus rail integrated in the profile rail at the left side of the CPU. Due to the parallel SPEED-Bus not all slots must be occupied in sequence.

##### SLOT 1 for additional power supply

At slot (SLOT 1 DCDC) you may plug either a SPEED-Bus module or an additional power supply.

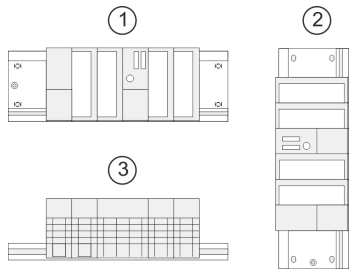
**Assembly possibilities**

You may assemble the System 300 horizontally, vertically or lying. Please regard the allowed environment temperatures:

- 1 horizontal assembly: from 0 to 60°C
- 2 vertical assembly: from 0 to 50°C
- 3 lying assembly: from 0 to 55°C

**3.2 Installation dimensions**

**Dimensions Basic enclosure** 1tier width (WxHxD) in mm: 40 x 125 x 120

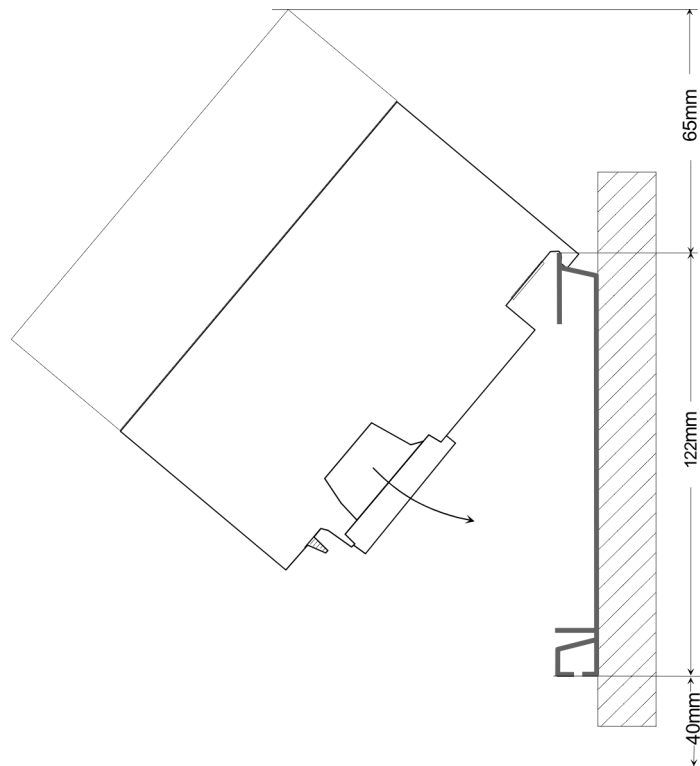
**Dimensions**

Installation dimensions

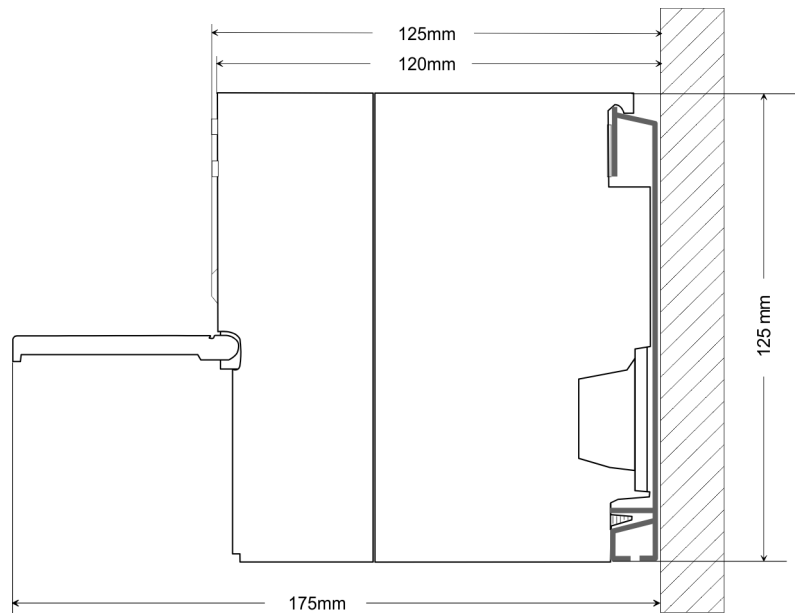

3.3 Assembly SPEED-Bus

Pre-manufactured SPEED-Bus profile rail

For the deployment of SPEED-Bus modules, a pre-manufactured SPEED-Bus rail is required. This is available mounted on a profile rail with 2, 6 or 10 extension slots.

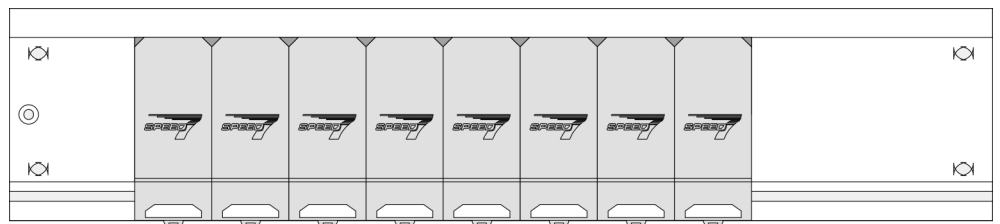

Dimensions

Order number	Number of modules SPEED-Bus/ Standard bus	A	B	C	D	E
391-1AF10	2/6	530	100	268	510	10
391-1AF30	6/2	530	100	105	510	10
391-1AF50	10/0	530	20	20	510	10
391-1AJ10	2/15	830	22	645	800	15
391-1AJ30	6/11	830	22	480	800	15
391-1AJ50	10/7	830	22	320	800	15

Measures in mm

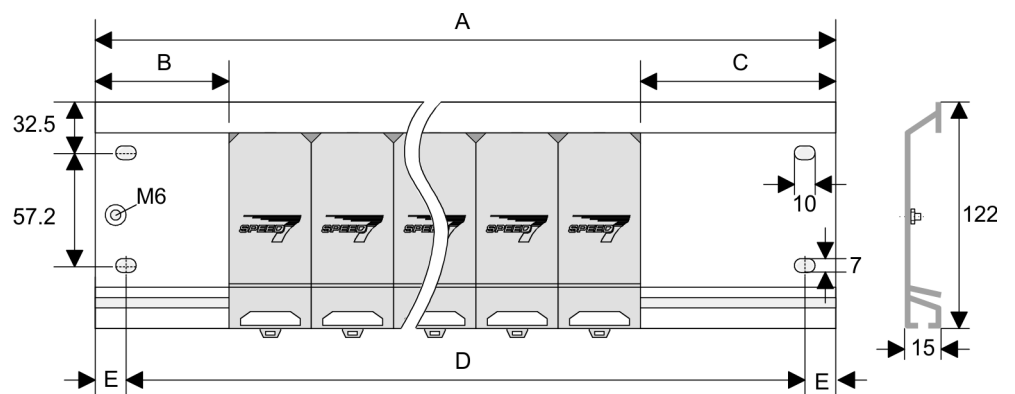

**Installation of the profile rail**

1. Bolt the profile rail with the background (screw size: M6), so that you still have minimum 65mm space above and 40mm below the profile rail. Please look for a low-impedance connection between profile rail and background.

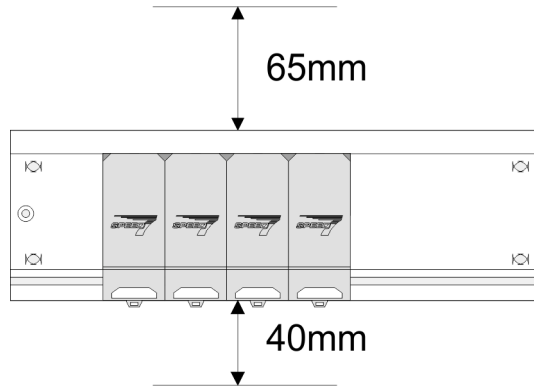

2. Connect the profile rail with the protected earth conductor. The minimum cross-section of the cable to the protected earth conductor has to be 10mm<sup>2</sup>.

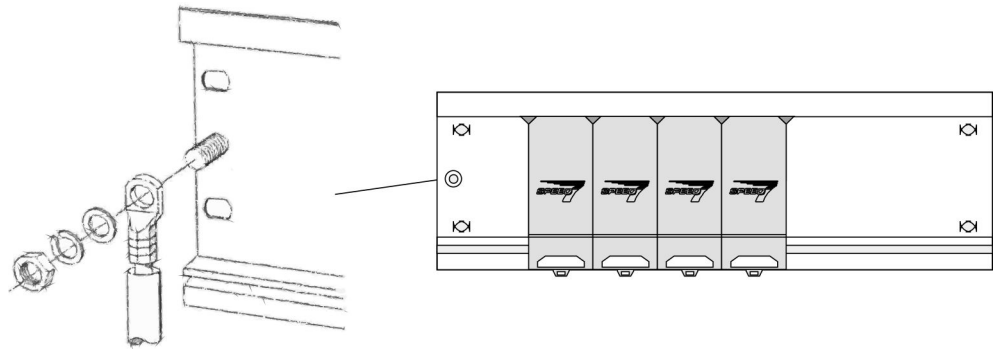

**Installation SPEED-Bus module**

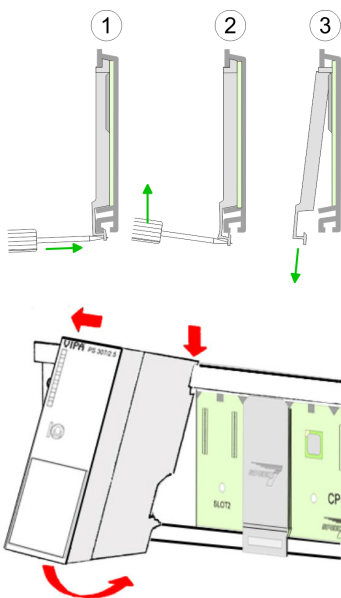

1. Dismantle the according protection flaps of the SPEED-Bus slot with a screw driver (open and pull down).  
For the SPEED-Bus is a parallel bus, not every SPEED-Bus slot must be used in series. Leave the protection flap installed at an unused SPEED-Bus slot.
2. At deployment of a DC 24V power supply, install it at the shown position at the profile rail at the left side of the SPEED-Bus and push it to the left to the isolation bolt of the profile rail.
3. Fix the power supply by screwing.

Assembly SPEED-Bus

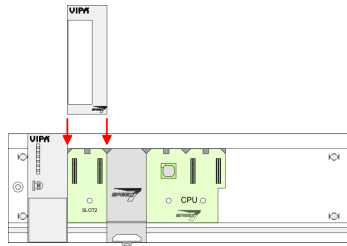

4. To connect the SPEED-Bus modules, plug it between the triangular positioning helps to a slot marked with "SLOT ..." and pull it down.
5. Only the "SLOT1 DCDC" allows you to plug-in either a SPEED-Bus module or an additional power supply.
6. Fix the CPU by screwing.

**Installation CPU without Standard-Bus-Modules**

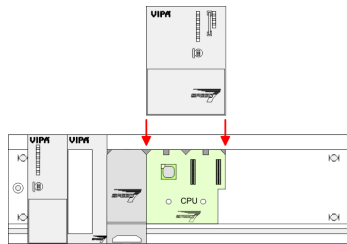

1. To deploy the SPEED7-CPU exclusively at the SPEED-Bus, plug it between the triangular positioning helps to the slot marked with "CPU SPEED7" and pull it down.

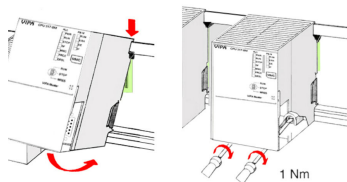

2. Fix the CPU by screwing.

**Installation CPU with Standard-Bus-Modules**

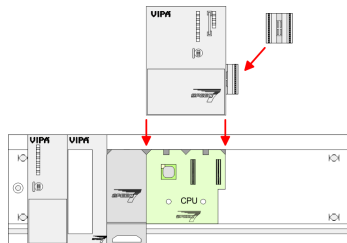

1. If also standard modules shall be plugged, take a bus coupler and click it at the CPU from behind like shown in the picture. Plug the CPU between the triangular positioning helps to the slot marked with "CPU SPEED7" and pull it down.

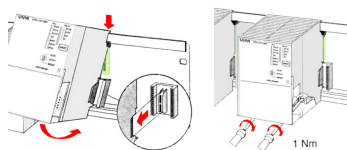

2. Fix the CPU by screwing.

**Installation Standard-Bus-Modules**

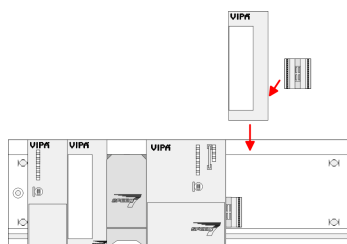

- Repeat this procedure with the peripheral modules, by clicking a backplane bus coupler, stick the module right from the modules you've already fixed, click it downwards and connect it with the backplane bus coupler of the last module and bolt it.



**CAUTION**

- The power supplies must be released before installation and repair tasks, i.e. before handling with the power supply or with the cabling you must disconnect current/voltage (pull plug, at fixed connection switch off the concerning fuse)!
- Installation and modifications only by properly trained personnel!

## 3.4 Industrial security and installation guidelines

### 3.4.1 Industrial security in information technology

#### Latest version

This chapter can also be found as a guide '*Industrial IT Security*' in the '*Download Center*' of [www.yaskawa.eu.com](http://www.yaskawa.eu.com)

#### Hazards

The topic of data security and access protection has become increasingly important in the industrial environment. The increased networking of entire industrial systems to the network levels within the company together with the functions of remote maintenance have all served to increase vulnerability. Hazards can arise from:

- Internal manipulation such as technical errors, operating and program errors and deliberate program or data manipulation.
- External manipulation such as software viruses, worms and trojans.
- Human carelessness such as password phishing.

#### Precautions

The most important precautions to prevent manipulation and loss of data security in the industrial environment are:

- Encrypting the data traffic by means of certificates.
- Filtering and inspection of the traffic by means of VPN - "Virtual Private Networks".
- Identification of the user by "Authentication" via save channels.
- Segmenting in protected automation cells, so that only devices in the same group can exchange data.
- Deactivation of unnecessary hardware and software.

#### Further Information

You can find more information about the measures on the following websites:

- Federal Office for Information Technology → [www.bsi.bund.de](http://www.bsi.bund.de)
- Cybersecurity & Infrastructure Security Agency → [us-cert.cisa.gov](http://us-cert.cisa.gov)
- VDI / VDE Society for Measurement and Automation Technology → [www.vdi.de](http://www.vdi.de)

### 3.4.1.1 Protection of hardware and applications

#### Precautions

- Do not integrate any components or systems into public networks.
  - Use VPN "Virtual Private Networks" for use in public networks. This allows you to control and filter the data traffic accordingly.
- Always keep your system up-to-date.
  - Always use the latest firmware version for all devices.
  - Update your user software regularly.
- Protect your systems with a firewall.
  - The firewall protects your infrastructure internally and externally.
  - This allows you to segment your network and isolate entire areas.
- Secure access to your plants via user accounts.
  - If possible, use a central user management system.
  - Create a user account for each user for whom authorization is essential.
  - Always keep user accounts up-to-date and deactivate unused user accounts.
- Secure access to your plants via secure passwords.
  - Change the password of a standard login after the first start.
  - Use strong passwords consisting of upper/lower case, numbers and special characters. The use of a password generator or manager is recommended.
  - Change the passwords according to the rules and guidelines that apply to your application.
- Deactivate inactive communication ports respectively protocols.
  - Only the communication ports that are used for communication should be activated.
  - Only the communication protocols that are used for communication should be activated.
- Consider possible defence strategies when planning and securing the system.
  - The isolation of components alone is not sufficient for comprehensive protection. An overall concept is to be drawn up here, which also provides defensive measures in the event of a cyber attack.
  - Periodically carry out threat assessments. Among others, a comparison is made here between the protective measures taken and those required.
- Limit the use of external storage media.
  - Via external storage media such as USB memory sticks or SD memory cards, malware can get directly into a system while bypassing a firewall.
  - External storage media or their slots must be protected against unauthorized physical access, e.g. by using a lockable control cabinet.
  - Make sure that only authorized persons have access.
  - When disposing of storage media, make sure that they are safely destroyed.
- Use secure access paths such as HTTPS or VPN for remote access to your plant.
- Enable security-related event logging in accordance with the applicable security policy and legal requirements for data protection.

### 3.4.1.2 Protection of PC-based software

#### Precautions

Since PC-based software is used for programming, configuration and monitoring, it can also be used to manipulate entire systems or individual components. Particular caution is required here!

- Use user accounts on your PC systems.
  - If possible, use a central user management system.
  - Create a user account for each user for whom authorization is essential.
  - Always keep user accounts up-to-date and deactivate unused user accounts.
- Protect your PC systems with secure passwords.
  - Change the password of a standard login after the first start.
  - Use strong passwords consisting of upper/lower case, numbers and special characters. The use of a password generator or manager is recommended.
  - Change the passwords according to the rules and guidelines that apply to your application.
- Enable security-related event logging in accordance with the applicable security policy and legal requirements for data protection.
- Protect your PC systems by security software.
  - Install virus scanners on your PC systems to identify viruses, trojans and other malware.
  - Install software that can detect phishing attacks and actively prevent them.
- Always keep your software up-to-date.
  - Update your operating system regularly.
  - Update your software regularly.
- Make regular backups and store the media at a safe place.
- Regularly restart your PC systems. Only boot from storage media that are protected against manipulation.
- Use encryption systems on your storage media.
- Perform security assessments regularly to reduce the risk of manipulation.
- Use only data and software from approved sources.
- Uninstall software which is not used.
- Disable unused services.
- Activate a password-protected screen lock on your PC systems.
- Always lock your PC systems as soon as you leave your PC workstation.
- Do not click any links that come from unknown sources. If necessary ask, e.g. on e-mails.
- Use secure access paths such as HTTPS or VPN for remote access to your PC system.

### 3.4.2 Installation guidelines

#### General

The installation guidelines contain information about the interference free deployment of a PLC system. There is the description of the ways, interference may occur in your PLC, how you can make sure the electromagnetic compatibility (EMC), and how you manage the isolation.

#### What does EMC mean?

Electromagnetic compatibility (EMC) means the ability of an electrical device, to function error free in an electromagnetic environment without being interfered respectively without interfering the environment.

The components are developed for the deployment in industrial environments and meets high demands on the EMC. Nevertheless you should project an EMC planning before installing the components and take conceivable interference causes into account.

**Possible interference causes**

Electromagnetic interferences may interfere your control via different ways:

- Electromagnetic fields (RF coupling)
- Magnetic fields with power frequency
- Bus system
- Power supply
- Protected ground conductor

Depending on the spreading medium (lead bound or lead free) and the distance to the interference cause, interferences to your control occur by means of different coupling mechanisms.

There are:

- galvanic coupling
- capacitive coupling
- inductive coupling
- radiant coupling

**Basic rules for EMC**

In the most times it is enough to take care of some elementary rules to guarantee the EMC. Please regard the following basic rules when installing your PLC.

- Take care of a correct area-wide grounding of the inactive metal parts when installing your components.
  - Connect all inactive metal extensive and impedance-low.
  - Please try not to use aluminium parts. Aluminium is easily oxidizing and is therefore less suitable for grounding.
- When cabling, take care of the correct line routing.
  - Organize your cabling in line groups (high voltage, current supply, signal and data lines).
  - Always lay your high voltage lines and signal respectively data lines in separate channels or bundles.
  - Route the signal and data lines as near as possible beside ground areas (e.g. suspension bars, metal rails, tin cabinet).
- Proof the correct fixing of the lead isolation.
  - Data lines must be shielded.
  - Analog lines must be shielded. When transmitting signals with small amplitudes the one sided laying of the isolation may be favourable.
  - Cables for frequency inverters, servo and stepper motors must be shielded.
  - Lay the line isolation extensively on an isolation/protected ground conductor rail directly after the cabinet entry and fix the isolation with cable clamps.
  - Make sure that the isolation/protected ground conductor rail is connected impedance-low with the cabinet.
  - Use metallic or metallised plug cases for isolated data lines.
- In special use cases you should appoint special EMC actions.
  - Consider to wire all inductivities with erase links.
  - Please consider luminescent lamps can influence signal lines.
- Create a homogeneous reference potential and ground all electrical operating supplies when possible.
  - Please take care for the targeted employment of the grounding actions. The grounding of the PLC serves for protection and functionality activity.
  - Connect installation parts and cabinets with your PLC in star topology with the isolation/protected ground conductor system. So you avoid ground loops.
  - If there are potential differences between installation parts and cabinets, lay sufficiently dimensioned potential compensation lines.

## Isolation of conductors

Electrical, magnetically and electromagnetic interference fields are weakened by means of an isolation, one talks of absorption. Via the isolation rail, that is connected conductive with the rack, interference currents are shunt via cable isolation to the ground. Here you have to make sure, that the connection to the protected ground conductor is impedance-low, because otherwise the interference currents may appear as interference cause.

When isolating cables you have to regard the following:

- If possible, use only cables with isolation tangle.
- The hiding power of the isolation should be higher than 80%.
- Normally you should always lay the isolation of cables on both sides. Only by means of the both-sided connection of the isolation you achieve high quality interference suppression in the higher frequency area. Only as exception you may also lay the isolation one-sided. Then you only achieve the absorption of the lower frequencies. A one-sided isolation connection may be convenient, if:
  - the conduction of a potential compensating line is not possible.
  - analog signals (some mV respectively  $\mu\text{A}$ ) are transferred.
  - foil isolations (static isolations) are used.
- With data lines always use metallic or metallised plugs for serial couplings. Fix the isolation of the data line at the plug rack. Do not lay the isolation on the PIN 1 of the plug bar!
- At stationary operation it is convenient to strip the insulated cable interruption free and lay it on the isolation/protected ground conductor line.
- To fix the isolation tangles use cable clamps out of metal. The clamps must clasp the isolation extensively and have well contact.
- Lay the isolation on an isolation rail directly after the entry of the cable in the cabinet.



### CAUTION

#### Please regard at installation!

At potential differences between the grounding points, there may be a compensation current via the isolation connected at both sides.

Remedy: Potential compensation line

## 4 Hardware description

### 4.1 Properties

#### CP 343-1EX71

The CP in the following may only be used at the SPEED-Bus.

- Ethernet CP for SPEED-Bus
- With NetPro of Siemens SIMATIC manager configurable
- Siemens SIMATIC manager searching is supported
- NCM-Diagnostics via Ethernet is supported
- 16 configurable connections via Siemens NetPro
- 64 configurable connections via user program
- 32 PG/OP connections

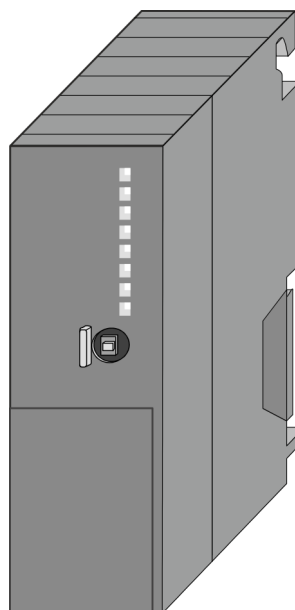

#### Order data

Type	Order number	Description
CP 343S-NET	343-1EX71	Ethernet CP 343S-NET for SPEED-Bus

## 4.2 Structure

### CP 343S-NET

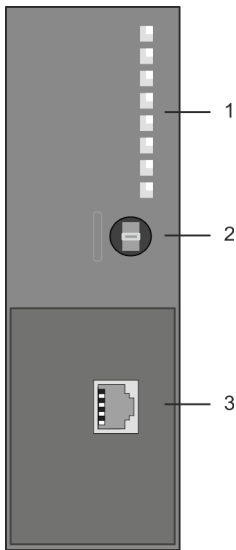

- 1 LED status indicators
  - 2 Operating mode switch
  - 3 Twisted pair interface for Ethernet
- The following components are under the front flap:**

### Interface

RJ45

X1

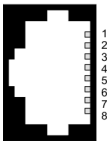

- ① Transmit +
- ② Transmit -
- ③ Receive +
- ④ -
- ⑤ -
- ⑥ Receive -
- ⑦ -
- ⑧ -

Via the RJ45 jack you may connect the CP 343-1EX71 - SPEED-Bus to Ethernet.

### Operating mode switch









The following operating modes can be set at the Ethernet CP 343S-NET by means of the operating switch:

- RUN
  - The CP is switched to RUN with the following behavior:
    - State RUN is indicated by LED
    - Configured connections are established
- STOP
  - The CP is switched to STOP with the following behavior:
    - State STOP is indicated by LED
    - Established connections are blocked
    - Project engineering and diagnostics are possible
    - PG channel routing remains exist

## Structure

**LEDs** The CP 343S-NET carries a number of LEDs that are available for diagnostic purposes on the bus and for displaying the local status. These give information according to the following pattern over the operating condition of the CP:

PWR	RUN	STOP	SF	L/A	S	Meaning
 green	 green	 gelb	 red	 green	 green	
<input type="checkbox"/>	<input type="checkbox"/>	<input type="checkbox"/>	<input type="checkbox"/>	<input type="checkbox"/>	<input type="checkbox"/>	CP is not power supplied, or there may be a defect.
<input checked="" type="checkbox"/>	<input type="checkbox"/>	<input type="checkbox"/>	<input checked="" type="checkbox"/>	X	X	Start-up (Communication via SPEED-Bus)
<input checked="" type="checkbox"/>	<input checked="" type="checkbox"/>	<input type="checkbox"/>	<input type="checkbox"/>	X	X	The CP is in RUN with a loaded project. The communication by configured connections is enabled.
<input checked="" type="checkbox"/>	<input type="checkbox"/>	<input checked="" type="checkbox"/>	<input type="checkbox"/>	X	X	CP is in STOP, the communication by configured connections is disabled or CP has no project and may exclusively be accessed by the MAC address.
<input checked="" type="checkbox"/>	X	X	X	<input checked="" type="checkbox"/>	X	CP is physically connected to Ethernet.
<input checked="" type="checkbox"/>	X	X	X	<input checked="" type="checkbox"/>	X	Flashing: Shows communication via Ethernet (activity).
<input checked="" type="checkbox"/>	X	X	X	<input type="checkbox"/>	<input type="checkbox"/>	There is no physically connection to Ethernet.
<input checked="" type="checkbox"/>	X	X	X	X	<input checked="" type="checkbox"/>	Speed: 100MBit
<input checked="" type="checkbox"/>	X	X	X	X	<input type="checkbox"/>	Speed: 10MBit

irrelevant: X

**Power supply** The CP 343-1EX71 gets its power supply via the SPEED-Bus.

→ [‘Technical data’...page 27](#)

**Firmware update** There is the possibility to execute a firmware update of the CP 343-1EX71 among others via the SPPED7 CPU by means of a memory card. So a firmware file may be recognized and assigned with startup, a pkg file name is reserved for each updateable component and hardware release, which begins with "px" and differs in a number with six digits. The pkg file name may be found at a label right down the front flap of the module.

**Project engineering** The project engineering of the Ethernet CP 343S-NET - SPEED-Bus takes place in the Siemens hardware configurator as CP 343-1 (343-1EX11). To configure connections Siemens NetPro should be used.

### 4.3 Technical data

<b>Order no.</b>	<b>343-1EX71</b>
Type	CP 343S TCP/IP, Ethernet-CP 343 SPEED-Bus
SPEED-Bus	✓
<b>Current consumption/power loss</b>	
Current consumption from backplane bus	500 mA
Power loss	2.5 W
<b>Status information, alarms, diagnostics</b>	
Status display	yes
Interrupts	no
Process alarm	no
Diagnostic interrupt	no
Diagnostic functions	no
Diagnostics information read-out	possible
Supply voltage display	green LED
Group error display	red SF LED
Channel error display	none
<b>Ethernet communication CP</b>	
Number of configurable connections, max.	64
Number of productive connections by Siemens NetPro, max.	16
S7 connections	USEND, URCV, BSEND, BRCV, GET, PUT, Connection of active and passive data handling
User data per S7 connection, max.	32 KB
TCP-connections	SEND, RECEIVE, FETCH PASSIV, WRITE PASSIV, Connection of active and passive data handling
User data per TCP connection, max.	64 KB
ISO-connections	SEND, RECEIVE, FETCH PASSIV, WRITE PASSIV, Connection of active and passive data handling
User data per ISO connection, max.	8 KB
ISO on TCP connections (RFC 1006)	SEND, RECEIVE, FETCH PASSIV, WRITE PASSIV, Connection of active and passive data handling
User data per ISO on TCP connection, max.	32 KB
UDP-connections	SEND and RECEIVE
User data per UDP connection, max.	2 KB
UDP-multicast-connections	SEND and RECEIVE (max. 16 Multicast groups)
UDP-broadcast-connections	SEND
<b>Functionality RJ45 interfaces</b>	
Type	X1
Type of interface	Ethernet 10/100 MBit
Connector	RJ45
Electrically isolated	✓
PG/OP channel	✓
Number of connections, max.	32
Productive connections	✓
<b>Housing</b>	
Material	PPE
Mounting	DIN rail SPEED-Bus
<b>Mechanical data</b>	

## Technical data

<b>Order no.</b>	<b>343-1EX71</b>
Dimensions (WxHxD)	40 mm x 125 mm x 120 mm
Net weight	165 g
Weight including accessories	-
Gross weight	-
<b>Environmental conditions</b>	
Operating temperature	0 °C to 60 °C
Storage temperature	-25 °C to 70 °C
<b>Certifications</b>	
UL certification	yes
KC certification	-
UKCA certification	yes
ChinaRoHS certification	yes

## 5 Deployment

### 5.1 Basics - Industrial Ethernet in automation

#### Overview

The flow of information in a company presents a vast spectrum of requirements that must be met by the communication systems. Depending on the area of business the bus system or LAN must support a different number of users, different volumes of data must be transferred and the intervals between transfers may vary, etc. It is for this reason that different bus systems are employed depending on the respective task. These may be subdivided into different classes. The following model depicts the relationship between the different bus systems and the hierarchical structures of a company:

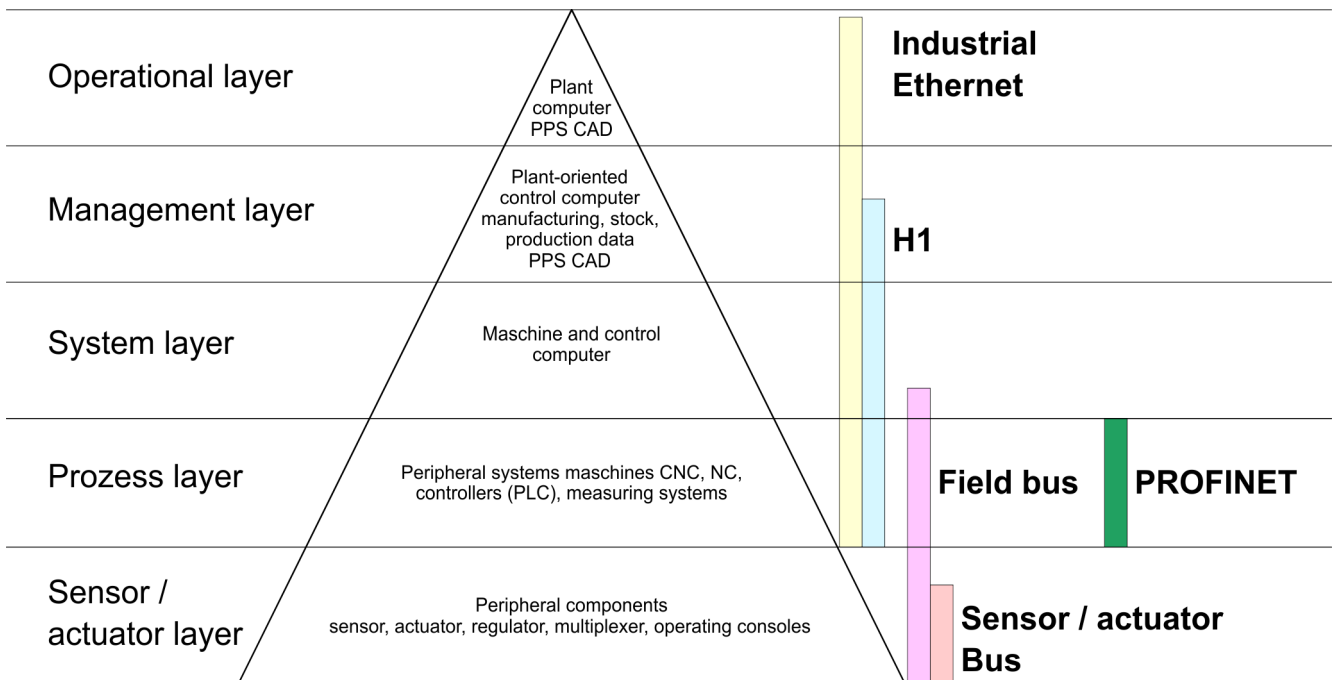

#### Industrial Ethernet

Industrial Ethernet is an electrical net based on shielded twisted pair cabling or optical net based on optical fibre. Industrial Ethernet is defined by the international standard IEEE 802.3

The net access of Industrial Ethernet corresponds to IEEE 802.3 - CSMA/CD (**C**arrier **S**ense **M**ultiple **A**ccess/**C**ollision **D**etection) scheme:

- Every station "listens" on the bus cable and receives communication messages that are addressed to it.
- Stations will only initiate a transmission when the line is unoccupied.
- In the event that two participants should start transmitting simultaneously, they will detect this and stop transmitting to restart after a random delay time has expired.
- Using switches there is the possibility for communication without collisions.

## 5.2 Basics - ISO/OSI reference model

### Overview

The ISO/OSI reference model is based on a proposal that was developed by the International Standards Organization (ISO). This represents the first step towards an international standard for the different protocols. It is referred to as the ISO-OSI layer model. OSI is the abbreviation for **O**pen **S**ystem **I**nterconnection, the communication between open systems. The ISO/OSI reference model does not represent a network architecture as it does not define the services and protocols used by the different layers. The model simply specifies the tasks that the different layers must perform. All current communication systems are based on the ISO/OSI reference model, which is defined by the ISO 7498 standard. The reference model structures communication systems into 7 layers that cover different communication tasks. In this manner the complexity of the communication between different systems is divided amongst different layers to simplify the task.

The following layers have been defined:

- Layer 7 - Application Layer
- Layer 6 - Presentation Layer
- Layer 5 - Session Layer
- Layer 4 - Transport Layer
- Layer 3 - Network Layer
- Layer 2 - Data Link Layer
- Layer 1- Physical Layer

Depending on the complexity and the requirements of the communication mechanisms a communication system may use a subset of these layers.

### Layer 1 - Bit communication layer (physical layer)

The bit communication layer (physical layer) is concerned with the transfer of data bits via the communication channel. This layer is therefore responsible for the mechanical, electrical and the procedural interfaces and the physical communication medium located below the bit communication layer:

- Which voltage represents a logical 0 or a 1?
- The minimum time the voltage is present to be recognized as a bit.
- The pin assignment of the respective interface.

### Layer 2 - Security layer (data link layer)

This layer performs error-checking functions for bit strings transferred between two communicating partners. This includes the recognition and correction or flagging of communication errors and flow control functions. The security layer (data link layer) converts raw communication data into a sequence of frames. This is where frame limits are inserted on the transmitting side and where the receiving side detects them. These limits consist of special bit patterns that are inserted at the beginning and at the end of every frame. The security layer often also incorporates flow control and error detection functions. The data security layer is divided into two sub-levels, the LLC and the MAC level. The MAC (**M**edia **A**ccess **C**ontrol) is the lower level and controls how senders are sharing a single transmit channel. The LLC (**L**ogical **L**ink **C**ontrol) is the upper level that establishes the connection for transferring the data frames from one device into the other.

### Layer 3 - Network layer

The network layer is an agency layer. Business of this layer is to control the exchange of binary data between stations that are not directly connected. It is responsible for the logical connections of layer 2 communications. Layer 3 supports the identification of the single network addresses and the establishing and disconnecting of logical communication channels. Additionally, layer 3 manages the prior transfer of data and the error processing of data packets. IP (Internet Protocol) is based on Layer 3.

### Layer 4 - Transport layer

Layer 4 connects the network structures with the structures of the higher levels by dividing the messages of higher layers into segments and passes them on to the network layer. Hereby, the transport layer converts the transport addresses into network addresses. Common transport protocols are: TCP, SPX, NWLink and NetBEUI.

<b>Layer 5 - Session layer</b>	The session layer is also called the communication control layer. It relieves the communication between service deliverer and the requestor by establishing and holding the connection if the transport system has a short time fail out. At this layer, logical users may communicate via several connections at the same time. If the transport system fails, a new connection is established if needed. Additionally this layer provides methods for control and synchronization tasks.
<b>Layer 6 - Presentation layer</b>	This layer manages the presentation of the messages, when different network systems are using different representations of data. Layer 6 converts the data into a format that is acceptable for both communication partners. Here compression/decompression and encrypting/decrypting tasks are processed. This layer is also called interpreter. A typical use of this layer is the terminal emulation.
<b>Layer 7 - Application layer</b>	The application layer is the link between the user application and the network. The tasks of the application layer include the network services like file, print, message, data base and application services as well as the according rules. This layer is composed from a series of protocols that are permanently expanded following the increasing needs of the user.

### 5.3 Basics - Terms

<b>Network (LAN)</b>	A network res. LAN (Local Area Network) provides a link between different stations that enables them to communicate with each other. Network stations consist of PCs, IPCs, TCP/IP adapters, etc. Network stations are separated by a minimum distance and connected by means of a network cable. The combination of network stations and the network cable represent a complete segment. All the segments of a network form the Ethernet (physics of a network).
<b>Twisted Pair</b>	In the early days of networking the Triaxial- (yellow cable) or thin Ethernet cable (Cheapernet) was used as communication medium. This has been superseded by the twisted-pair network cable due to its immunity to interference. The CPU has a twisted-pair connector. The twisted-pair cable consists of 8 cores that are twisted together in pairs. Due to these twists this system is provides an increased level of immunity to electrical interference. For linking please use twisted pair cable which at least corresponds to the category 5. Where the coaxial Ethernet networks are based on a bus topology the twisted-pair network is based on a point-to-point scheme. The network that may be established by means of this cable has a star topology. Every station is connected to the star coupler (hub/switch) by means of a separate cable. The hub/switch provides the interface to the Ethernet.
<b>Hub (repeater)</b>	The hub is the central element that is required to implement a twisted-pair Ethernet network. It is the job of the hub to regenerate and to amplify the signals in both directions. At the same time it must have the facility to detect and process segment wide collisions and to relay this information. The hub is not accessible by means of a separate network address since it is not visible to the stations on the network. A hub has provisions to interface to Ethernet or to another hub res. switch.
<b>Switch</b>	A switch also is a central element for realizing Ethernet on Twisted Pair. Several stations res. hubs are connected via a switch. Afterwards they are able to communicate with each other via the switch without interfering the network. An intelligent hardware analyses the incoming telegrams of every port of the switch and passes them collision free on to the destination stations of the switch. A switch optimizes the bandwidth in every connected segment of a network. Switches enable exclusive connections between the segments of a network changing at request.

## 5.4 Basics - Protocols

### Overview

Protocols define a set of instructions or standards that enable computer to establish communication connections and exchange information as error free as possible. A commonly established protocol for the standardization of the complete computer communication is the so called ISO/OSI layer model, a model based upon seven layers with rules for the usage of hardware and software → ['Basics - ISO/OSI reference model'...page 30](#)

The following protocols are used:

- Communication connections
  - Siemens S7 connections
  - TCP/IP
  - UDP
  - RFC1006 (ISO-ON-TCP)
  - ISO transport (once H1)

### Siemens S7 connections

With the Siemens S7 connection large data sets may be transferred between PLC systems based on Siemens STEP®7. Here the stations are connected via Ethernet. Precondition for the Siemens S7 communication is a configured connection table, which contains the defined connections for communication. Here NetPro from Siemens may be used.

Properties:

- A communication connection is specified by a connection ID for each connection partner.
- The acknowledgement of the data transfer is established from the partner station at level 7 of the ISO/OSI reference model.
- At the PLC side product specific FB/SFB handling blocks are necessary for data transfer for the Siemens S7 connections.



*More information about the usage of these blocks may be found in the manual "SPEED7 Operation List".*

## TCP/IP

TCP/IP protocols are available on all major systems. At the bottom end this applies to simple PCs, through to the typical mini-computer up to mainframes. For the wide spread of Internet accesses and connections, TCP/IP is often used to assemble heterogeneous system pools. TCP/IP (Transmission Control Protocol / Internet Protocol) collects a various range of protocols and functions. TCP and IP are only two of the protocols required for the assembly of a complete architecture.

### ■ TCP/IP

- The application layer provides programs like "FTP" and "Telnet" for the PC. The application layer of the Ethernet CP is defined with the user application using the standard handling blocks. These user applications use the transport layer with the protocols TCP or UDP for the data transfer which themselves communicate via the IP protocol with the Internet layer.
- Besides of the IP address ports are used for the addressing. A port address should be within the range of 2000...65535.
- Not depending on the used protocol, the PLC needs the product specific handling blocks AG\_SEND (FC 5) and AG\_RECV (FC 6) for data transfer.

### ■ IP

- IP covers the network layer (Layer 3) of the ISO/OSI layer model.
- The purpose of IP is to send data packages from on PC to another passing several other PCs. These data packages are referred to as datagrams. The IP doesn't neither guarantee the correct sequence of the datagrams nor the delivery at the receiver.
- For the unambiguous identification between sender and receiver 32Bit addresses (IP addresses) are used that are normally written as four octets (exactly 8bit), e.g. 172.16.192.11. These Internet addresses are defined and assigned worldwide, thus every user may communicate with all other TCP/IP users.
- One part of the address specifies the network; the rest serves the identification of the participants inside the network. The boarder between the network and the host part is variable and depends on the size of the network.
- To save IP addresses, so called NAT router are used that have one official IP address and cover the network. Then the network can use any IP address.

### ■ TCP

- TCP bases directly on the IP and thus covers the transport layer (layer 4) of the ISO/OSI layer model.
- TCP is a connection orientated end-to-end protocol and serves the logic connection between two partners.
- TCP guarantees the correct sequence and reliability of the data transfer. Therefore you need a relatively large protocol overhead that slows down the transfer speed
- Every datagram gets a header of at least 20Byte. This header also contains a sequence number identifying the series. This has the consequence that the single datagrams may reach the destination on different ways through the network.
- Using TCP connections, the telegram length is not transmitted. This means that the recipient has to know how many bytes belong to a message.
- To transfer data with variable length you may begin the user data with the length information and evaluate this at the counter station.

## UDP

UDP (User Datagramm Protocol) is a connection free transport protocol. It has been defined in the RFC768 (Request for Comment). Compared to TCP, it has much fewer characteristics. The addressing happens via port numbers. UDP is a fast unsafe protocol for it doesn't neither care about missing data packages nor about their sequence.

**ISO-on-TCP RFC1006**

The TCP transport service works stream orientated. This means that data packages assembled by the user not necessarily have to receive the partner in the same packaging. Depending on the data amount, packages may though come in the correct sequence but differently packed. This causes that the recipient may not recognize the package borders anymore. For example you may send 2x 10Byte packages but the counter station receives them as 20Byte package. But for most of the applications the correct packaging is important. Due to this you need another protocol above TCP. This purpose is defined in the protocol extension RFC1006 (ISO-on-TCP).

- RFC1006 describes the function of an ISO transport interface (ISO 8072) basing upon the transport interface TCP (RFC793).
- The basic protocol of RFC1006 is nearly identical to TP0 (Transport Protocol, Class 0) in ISO 8073.
- For RFC1006 is run as protocol for TCP, the decoding takes place in the data section of the TCP package.
- In contrast to TCP here the receipt of a telegram is confirmed.
- Instead of ports TSAPs are used for the addressing besides of the IP address. The TSAP length may be 1 ... 16 characters. The entry may happen in ASCII or Hex format.
- Not depending on the used protocol, the PLC needs the product specific handling blocks AG\_SEND (FC 5) and AG\_RECV (FC 6) for data transfer.
- Contrary to TCP different telegram lengths can be received using RFC1006.

**ISO transport (once H1)**

With ISO transport connections there is the possibility for program and event controlled communication via Industrial Ethernet. Here data blocks may be exchanged bi-directional. The ISO transport connection offers services for a safety transfer of data by means of configured connections. Large data blocks may be transferred by means of blocking. The transmission reliability is very high by the automatic repetition, by additional block test mechanisms and by the receipt acknowledgement at the receiver side.

- The ISO transport service (ISO 8073 class 4) corresponds to the transport layer (Layer 4) of the ISO/OSI reference model.
- ISO transport connections are exclusively transferred via Industrial Ethernet and they are optimized for the deployment in a closed manufacturing area.
- The receipt of data is acknowledged by the partner station. Here different telegram lengths may be processed.
- For deployment of the ISO transport connections they must be enabled in the Ethernet properties of the CP within your project. Here there is the possibility to assign the CP to a MAC address.
- The addressing happens by MAC address (Ethernet address) and TSAPs (Transport Service Access Point).
- The data transfer is made by the services SEND/RECEIVE and FETCH/WRITE.
- Not depending on the used protocol, the PLC needs the product specific handling blocks AG\_SEND (FC 5) and AG\_RECV (FC 6) for data transfer.

**5.5 Basics - IP address and subnet****IP address structure**

Exclusively IPv4 is supported. At IPv4 the IP address is a 32bit address that must be unique within the network and consists of 4 numbers that are separated by a dot. Every IP address is a combination of a *Net-ID* and a *Host-ID* and has the following structure: **xxx.xxx.xxx.xxx**

Range: 000.000.000.000 to 255.255.255.255

**Net-ID, Host-ID**

The **Network-ID** identifies a network res. a network controller that administrates the network. The **Host-ID** marks the network connections of a participant (host) to this network.

**Subnet mask**

The Host-ID can be further divided into a *Subnet-ID* and a new *Host-ID* by using a bit for bit AND assignment with the Subnet mask.

The area of the original Host-ID that is overwritten by 1 of the Subnet mask becomes the Subnet-ID, the rest is the new Host-ID.

Subnet mask	binary all "1"		binary all "0"
IPv4 address	Net-ID	Host-ID	
Subnet mask and IPv4 address	Net-ID	Subnet-ID	new Host-ID

**Address at first start-up**

At the first start-up the Ethernet CP 343-1EX71 - SPEED-Bus does not have an IP address. The are following possibilities for address assignment:

- Set the PG/PC interface of the Siemens SIMATIC manager to "TCP/IP..RFC1006" and search and assign address by means of "Assign Ethernet Address". After the assignment the IP parameters are set immediately without CPU restart.
- At the first start-up you may assign an IP address and a subnet mask to your CP by means of a "minimum project" and transfer this via memory card or MPI into the CPU. After a reboot of the CPU and after switching the PG/PC interface to "TCP/IP... RFC1006" you may now configure your CPU online via the CP.

**Address classes**

For IPv4 addresses there are five address formats (class A to class E) that are all of a length of 4byte = 32bit.

Class A	0	Network-ID (1+7bit)	Host-ID (24bit)
Class B	10	Network-ID (2+14bit)	Host-ID (16bit)
Class C	110	Network-ID (3+21bit)	Host-ID (8bit)
Class D	1110	Multicast group	
Class E	11110	Reserved	

The classes A, B and C are used for individual addresses, class D for multicast addresses and class E is reserved for special purposes. The address formats of the 3 classes A, B, C are only differing in the length of Network-ID and Host-ID.

**Private IP networks**

These addresses can be used as net-ID by several organizations without causing conflicts, for these IP addresses are neither assigned in the Internet nor are routed in the Internet. To build up private IP-Networks within the Internet, RFC1597/1918 reserves the following address areas (Host-ID is underlined):

Class	from IP	to IP	Standard subnet mask
A	10.0.0.0	10.255.255.255	255.0.0.0
B	172.16.0.0	172.31.255.255	255.255.0.0
C	192.168.0.0	192.168.255.255	255.255.255.0

**Reserved Host-IDs**

Some Host-IDs are reserved for special purposes.

Host-ID = "0"	Identifier of this network, reserved!
Host-ID = maximum (binary complete "1")	Broadcast address of this network



*Never choose an IP address with Host-ID=0 or Host-ID=maximum! (e.g. for class B with subnet mask = 255.255.0.0, the "172.16.0.0" is reserved and the "172.16.255.255" is occupied as local broadcast address for this network.)*

## 5.6 Basics - MAC address and TSAP

### MAC address

There is a unique MAC address (**Media Access Control**) necessary for each CP. Usually a module is labelled with its MAC address by the manufacturer. This address should be used for project engineering of the CP. The MAC address has a length of 6bytes. On delivery the first three bytes specify the manufacturer. These bytes are assigned by the IEEE committee. The last 3 bytes may be assigned by the manufacturer. In a network several stations with the same MAC address may not exist. The MAC address may be changed at any time. You will get a valid MAC address from your network administrator.

- Broadcast address
  - The MAC address, with which all bits are set to 1, is:  
FF-FF-FF-FF-FF-FF  
This address is used as Broadcast address and addresses all participants in the net.
- Address at first start-up
  - At the first-start-up the Ethernet CP 343S-NET - SPEED-Bus has an unique MAC address. This may be found on a label beneath the front flap.



*Please regard for the configuration of the network in the Siemens SIMATIC manager that it is necessary to activate the ISO protocol and to preset a valid MAC address within the properties dialog of the Ethernet interface of the CP!*

### TSAP

TSAP means **T**ransport **S**ervice **A**ccess **P**oint. ISO transport connections support TSAP length of 1 ... 16byte. TSAPs may be entered in ASCII format or hexadecimal.

### Address parameters

Station A				Station B
remote TSAP	→	ISO transport	→	local TSAP
local TSAP	←	connection	←	remote TSAP
MAC address A				MAC address B

An ISO transport connection is specified by a local and a remote connection endpoint. The TSAPs of an ISO transport connection must match as follows:

- Remote TSAP (in CP) = local TSAP (in destination station)
- Local TSAP (in CP) = remote TSAP (in destination station)

## 5.7 Fast introduction

### Overview

At the first start-up respectively at an over all reset the Ethernet CP 343S-NET - SPEED-Bus *does not have* any IP address. The CP may only be contacted by its MAC address. IP address parameters may be assigned to the CP by means of the MAC address, which may be found on a label beneath its front flap. The assignment takes place directly via the hardware configuration of the Siemens SIMATIC manager. For the project engineering of an Ethernet CP - SPEED-Bus please follow this approach:

1. **Assembly and commissioning**
2. **Hardware configuration** (Inclusion of CP in CPU)
3. **CP project engineering** via NetPro (connection to Ethernet)
4. **PLC programming** via user application (connection to PLC)
5. **Transfer of the complete project to the CPU**



To be compatible to the Siemens SIMATIC manager, the CPU 31xS from Yaskawa has to be configured via the corresponding Siemens CPU!

The Ethernet CP 343S-NET - SPEED-Bus is configured and connected as virtual module after the really plugged modules and below the PG/OP channel at the standard bus as Siemens CP 343-1 (343-1EX11). In addition the Ethernet CP 343S-NET - SPEED-Bus is to be placed as single VIPA\_SPEEDBUS DP slave at a virtually DP master.

### Assembly and commissioning

1. → Install your System 300S with a CPU 31xS and an Ethernet CP 343S-NET - SPEED-Bus.
2. → Wire the system by connecting cables for voltage supply, signals and Ethernet.  
→ [‘Assembly and installation guidelines’...page 14](#)
3. → Switch Power ON.
  - ➔ After a short boot time, the CP is in idle mode.
4. → At the first start-up res. after an overall reset of the CPU the Ethernet CP 343S-NET - SPEED-Bus does not have an IP address. For control purposes you may now reach the CP via the MAC address. The MAC address is to be found beneath the front flap at a small label on the module.

### Assign IP parameters

You get valid IP address parameters from your system administrator. For the assignment of the IP address parameters such as IP address, Subnet mask etc. you have the following possibilities:

- Online using Siemens SIMATIC manager via "Assign Ethernet Address" (at least CP-Firmware 1.7.4).
- With a project with IP address and IP parameters transferred via MMC or MPI to the CPU. After a reboot of the CPU and after switching the PG/PC interface to "TCP/IP... RFC1006" you may now configure your CPU online via the CP.

### Address assignment with "Assign Ethernet Address"

Please regard this functionality is available with CP firmware version 1.7.4 and up. In the following the proceeding with the Siemens SIMATIC manager starting with version V 5.3 & SP3 is described:

1. → Start the Siemens SIMATIC manager.
2. → Switch to "TCP/IP... RFC1006" using *‘Options → Set PG/PC interface’*.
3. → The dialog for initialization of a station opens by *‘PLC → Edit Ethernet Node’*.
4. → To get the stations and their MAC address, use the [Browse] button or type in the MAC Address. The Mac address can be found at a label beneath the front flap of the CP.
5. → Choose if necessary the known MAC address of the list of found stations.
6. → Either type in the IP configuration like IP address, subnet mask and gateway. Or your station is automatically provided with IP parameters by means of a DHCP server. Depending of the chosen option the DHCP server is to be supplied with MAC address, equipment name or client ID. The client ID is a numerical order of max. 63 characters. The following characters are allowed: "hyphen", 0-9, a-z, A-Z
7. → Confirm with [Assign ...].
  - ➔ Directly after the assignment the CP is online reachable using the set IP parameters.

**Address assignment with project**

1. Start Siemens SIMATIC manager with new project.
2. Place a new System 300 station with 'Insert → Station → SIMATIC 300 station'.
3. Activate the station "SIMATIC 300" and open the hardware configurator by clicking on "Hardware".
4. Configure a rack (SIMATIC 300 \ Rack-300 \ Profile rail).
5. Engineer in deputy of your CPU 31xS the corresponding Siemens CPU which is to be found at SIMATIC 300 \ CPU 300.
6. Place the System 300 modules in plugged sequence starting with slot 4.
7. Configure the internal PG/OP channel directly under the really plugged modules as virtual **CP 343-1 (343-1EX11)** from Siemens and set IP address, subnet mask and gateway at CP properties.
8. If used always configure as 2. CP the internal CP 343 of a CPU 31xSN/NET as **CP 343-1 (343-1EX11)** by setting another IP address, subnet mask and gateway. Else configure as 2. CP the Ethernet CP - SPEED-Bus as **CP 343-1 (343-1EX11)** by setting another IP address, subnet mask and gateway.
9. Please always assign valid IP parameters when using CPs.
10. A Siemens CP 342-5 (342-5DA02 V5.0) operating as DP master should be set and connected as last module.
11. To this master system you assign every SPEED-Bus module as VIPA\_SPEEDBUS slave. Here the PROFIBUS address corresponds to the slot no. Beginning with 100 for the CPU. Place on slot 0 of every slave the assigned module and alter the parameters if needed.
  - ➔ This is the end of the project. After transmission to the CPU the CP can be accessed using the IP address and subnet mask of the project.

**Deployment of ISO transport connections**

For deployment of the ISO transport connections they must be enabled in the Ethernet properties of the CP at the project above. Here there is the possibility to assign the CP to a MAC address. With each start-up of the CPU the new MAC address is transferred to the CP.

**Configure connections with NetPro**

The link-up between the stations happens with the graphical interface NetPro. Start NetPro by clicking on a network in your project res. on connections in the CPU directory.

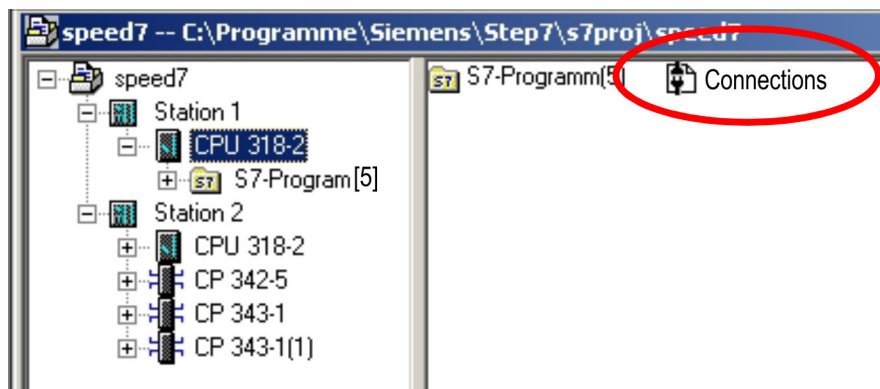

1. *Link-up stations*

For the project engineering of connections, connected stations are presumed. To link-up stations, point on the colored net mark of the according CP with the mouse and drag it to the network you want to assign. The connection is displayed graphically by a line.

## 2. → Configure connections

For the project engineering of new connections click on the according CPU and choose "Insert new connection" from the context menu.

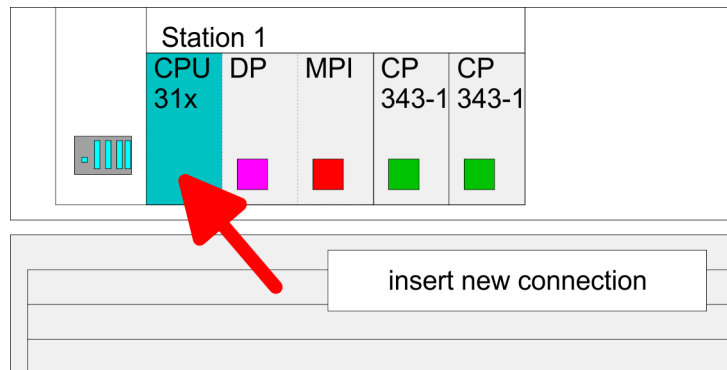

- ➔ Via the dialog window you may set the parameters for a connection. The parameters ID and LADDR are required for the usage on the blocks AG\_SEND res. AG\_RECV. With deployment of Siemens S7 connections the parameter ID is to be passed to the respective Yaskawa FB/SFB handling blocks.



### **Always use the 2. CP from the route**

Please take care to always choose the 2. CP from the route for communication. As 1. CP you will always see the Ethernet PG/OP channel that does not support configurable connections.

## 3. → Save and compile connections

Save and compile your project and close NetPro. To store the CP project engineering data in the system data, you have to activate the option "Save configuration data on the CPU" (default setting) under *object properties* area *Options* in the hardware configuration of the CP.

## PLC user application

For the execution of connection commands at the PLC, your CPU requires an user application. For this, exclusively the Yaskawa handling blocks are used, which you may get from Yaskawa as a library. Depending upon the connection type there are function blocks for Siemens S7 connections and Send/Receive connections.



More information about the usage of these blocks may be found in the manual "SPEED7 Operation List".

## Transfer project

There are 3 possibilities to transfer your project into the CPU:

- Transfer via MPI
- Transfer via memory card
- Transfer via integrated Ethernet PG/OP channel

## 5.8 Addressing at SPEED-Bus

### Overview

To provide specific addressing of the installed peripheral modules, certain addresses must be allocated in the CPU. With no hardware configuration present, the CPU assigns automatically peripheral I/O addresses during boot procedure depending on the plug-in location amongst others also for plugged modules at the SPEED-Bus.

### Maximal pluggable modules

In the hardware configurator from Siemens up to 8 modules per row may be parameterized. At deployment of SPEED7 CPUs up to 32 modules at the standard bus and 10 further modules at the SPEED-Bus may be controlled. CPs and DP masters that are additionally virtual configured at the standard bus are taken into the sum of 32 modules at the standard bus. For the project engineering of more than 8 modules you may use virtual line interface connections. For this you set in the hardware configurator the module IM 360 from the hardware catalog to slot 3 of your 1. profile rail. Now you may extend your system with up to 3 profile rails by starting each with an IM 361 from Siemens at slot 3.

### Define addresses by hardware configuration

You may access the modules with read res. write accesses to the peripheral bytes or the process image. To define addresses a hardware configuration via a virtual PROFIBUS system by including the SPEEDBUS.GSD may be used. For this, click on the properties of the according module and set the wanted address.

### Automatic addressing

If you do not like to use a hardware configuration, an automatic addressing comes into force. At the automatic address allocation DI/Os are mapped depending on the slot location with a distance of 4byte and AI/Os, FMs, CPs with a distance of 256byte.

Depending on the slot location the start address from where on the according module is stored in the address range is calculated with the following formulas:

- DI/Os: Start address =  $4 \times (\text{slot} - 101) + 128$
- AI/Os, FMs, CPs: Start address =  $256 \times (\text{slot} - 101) + 2048$

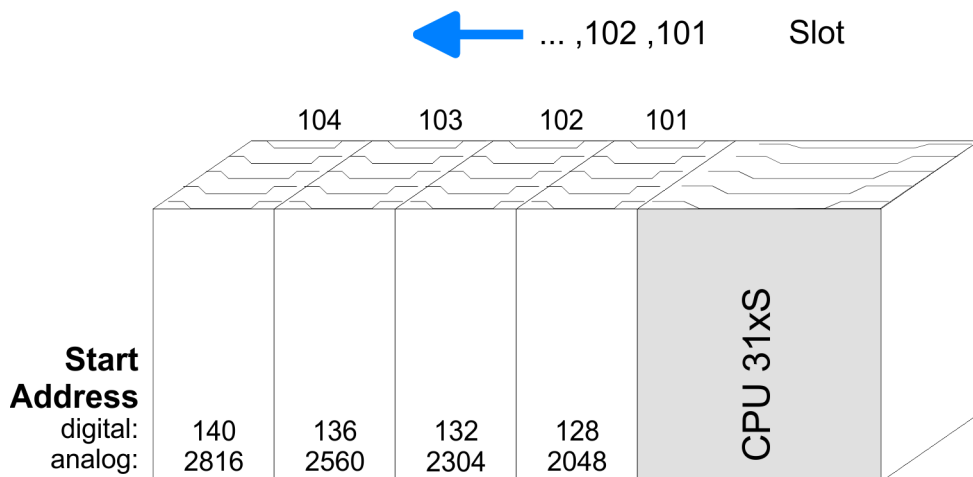

## 5.9 Hardware configuration

### Overview

The project engineering of the Ethernet CP 343S-NET - SPEED-Bus takes place at the Siemens hardware configurator and is divided into 2 parts:

- Project engineering and connecting at the standard bus as Siemens CP 343-1 (343-1EX11).
- Project engineering as single VIPA\_SPEEDBUS DP slave with CP 343-1EX71 at a virtually DP master (SPEEDBUS.GSD necessary).

## 5.9.1 Fast introduction

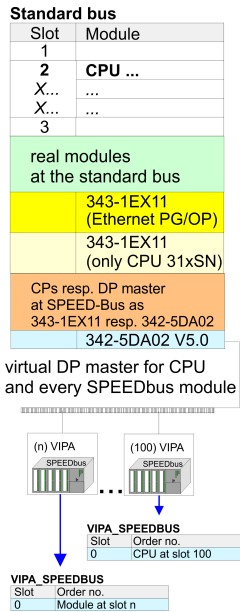

For the deployment of the Ethernet CP 343-1EX71 at the SPEED-Bus, the inclusion via the GSD-file in the hardware catalog is required. To be compatible with the Siemens SIMATIC manager, you have to execute the following steps:

1. Start the hardware configurator from Siemens and include the SPEEDBUS.GSD for SPEED7 .
2. Configure the corresponding CPU from Siemens. Configure a possibly existing internal DP master of your SPEED7-CPU via the internal DP master of the CPU. Leave MPI/DP of the CPU in MPI mode. The PROFIBUS mode is not supported.
3. Starting with slot 4, place the System 300 modules in the plugged sequence.
4. For the internal Ethernet PG/OP channel that every SPEED7-CPU includes, you have to configure a Siemens CP 343-1 (343-1EX11) always as 1. module below the really plugged modules.
5. If exists the integrated CP 343 of the CPU 31xSN/NET is also configured as CP 343-1 (343-1EX11) but always below the before configured PG/OP channel. Else start here to configure and connect every Ethernet CP 343-1EX71 - SPEED-Bus as Siemens CP 343-1 (343-1EX11).
6. For the SPEED-Bus you always include, connect and parameterize to the operating mode DP master the DP master CP 342-5 (342-5DA02 V5.0) as last module. To this master system you assign every SPEED-Bus module as VIPA\_SPEEDBUS slave. Here the PROFIBUS address corresponds to the slot number. Beginning with 100 for the CPU. Place on slot 0 of every slave the assigned module and alter the parameters if needed.
7. Let with the CPs or DP master (also virtual SPEED-Bus master) at *options* the attitude "Save configuration data on the CPU" activated!

## 5.9.2 Requirements

The hardware configurator is a part of the Siemens SIMATIC manager. It serves the project engineering. The modules that may be configured here are listed in the hardware catalog. For the deployment of the System 300S modules at the SPEED-Bus, the inclusion via the GSD-file SPEEDBUS.GSD in the hardware catalog is required.



*For the project engineering a thorough knowledge of the SIMATIC manager and the hardware configurator from Siemens are required and assumed!*

**Installation of the SPEEDBUS.GSD**

The GSD (Geräte-Stamm-Datei) is online available in the following language versions. Further language versions are available on inquiries:

Name	Language
SPEEDBUS.GSD	German (default)
SPEEDBUS.GSG	German
SPEEDBUS.GSE	English

The GSD files may be found at [www.yaskawa.eu.com](http://www.yaskawa.eu.com) in the 'Download Center'.

The integration of the SPEEDBUS.GSD takes place with the following proceeding:

1. Go to [www.yaskawa.eu.com](http://www.yaskawa.eu.com).
2. Load in the 'Download Center' under 'PROFIBUS' the according setting file for your System 300S.
3. Extract the file to your work directory.
4. Start the hardware configurator from Siemens.
5. Close every project.
6. Select 'Options → Install new GSD-file'.
7. Navigate to the directory VIPA\_System\_300S and select **SPEEDBUS.GSD** an.
  - ➔ The SPEED7 CPUs and modules of the System 300S may now be found in the hardware catalog at PROFIBUS-DP / Additional field devices / I/O / VIPA\_SPEEDBUS.

**5.9.3 Steps of project engineering**

The following text describes the approach of the project engineering in the hardware configurator from Siemens at an abstract sample. The project engineering is separated into the following parts:

1. Project engineering of the Yaskawa via the corresponding Siemens CPU.
2. Project engineering of the real plugged modules at the standard bus.
3. Project engineering of the Ethernet PG/OP channel. When using CPU 31xSN/NET project engineering and connecting the CP part as Siemens CP 343-1EX11.
4. Project engineering and connecting of every Ethernet CP 343S-NET - SPEED-Bus at the standard bus as 343-1EX11 from Siemens.
5. Project engineering of every SPEED-Bus module as virtual PROFIBUS network. Here the SPEEDBUS.GSD is necessary.

**Hardware**

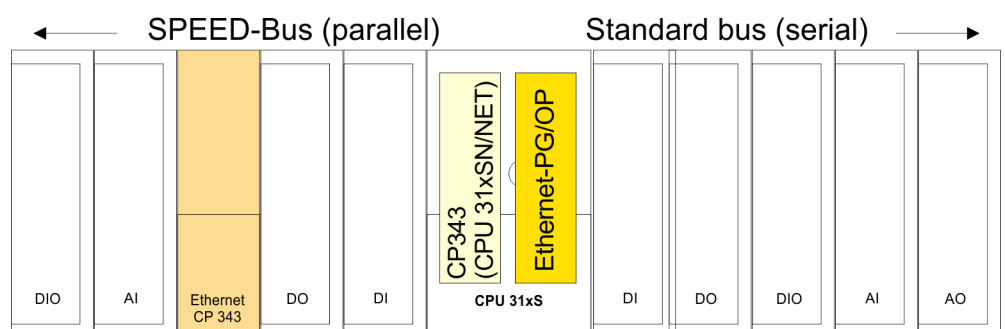

**Project engineering CPU**

1. Start the hardware configurator from Siemens with a new project and insert a profile rail from the hardware catalog.
2. Place the corresponding Siemens CPU at slot 2.
3. Configure a possibly existing internal DP master of your SPEED7-CPU via the internal DP master of the CPU. Leave *MPI/DP* of the CPU in *MPI* mode. The *PROFIBUS* mode is not supported.

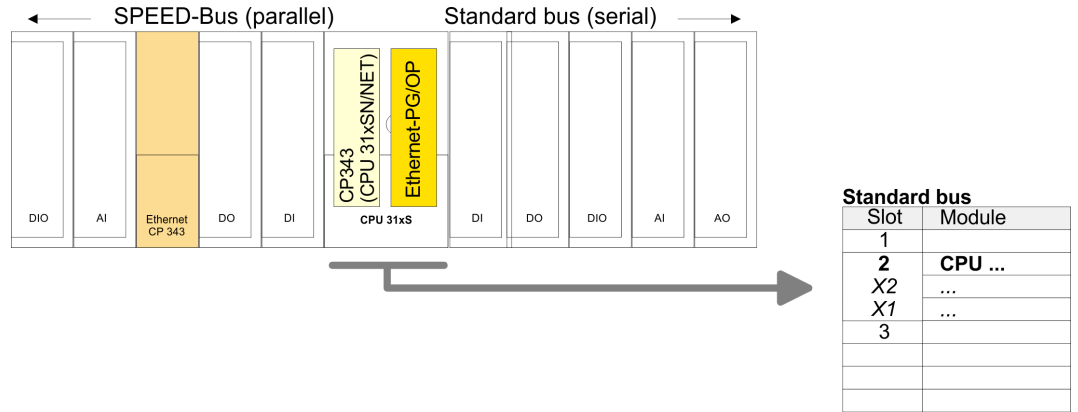

**Project engineering of the real modules at the standard bus**

The modules at the right side of the CPU at the standard bus are configured with the following approach:

1. Include your System 300 modules at the standard bus in the plugged sequence starting with slot 4.
2. Parameterize the CPU res. the modules where appropriate. The parameter window opens by a double click on the according module.

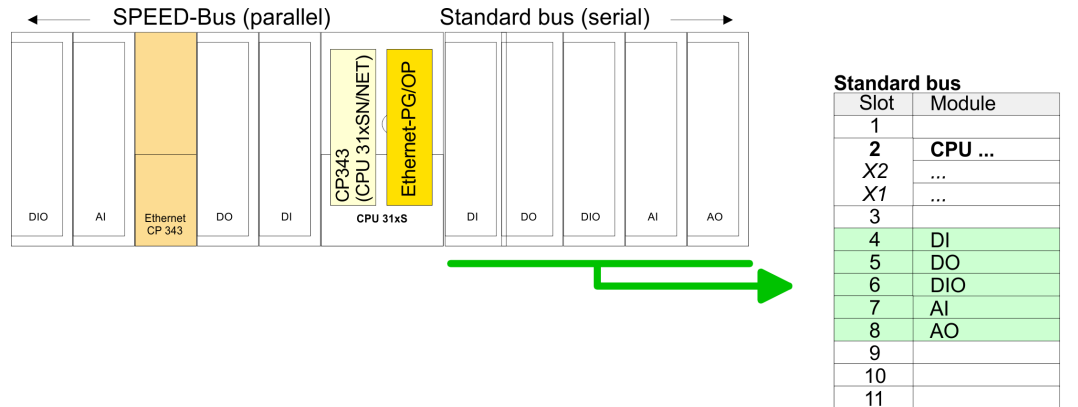

**Project engineering of Ethernet PG/OP channel and CP 343 as 343-1EX11**

For the internal Ethernet PG/OP channel that every SPEED7-CPU includes, you have to configure a Siemens CP 343-1 (343-1EX11) always as 1. module below the really plugged modules. If exists the integrated CP 343 of the CPU 31xSN/NET is also configured and connected as CP 343-1 (343-1EX11) but always below the before configured PG/OP channel. Else start here to configure and connect every integrated CP 343 from the CPU 31xSN/NET as Siemens CP 343-1 (343-1EX11).

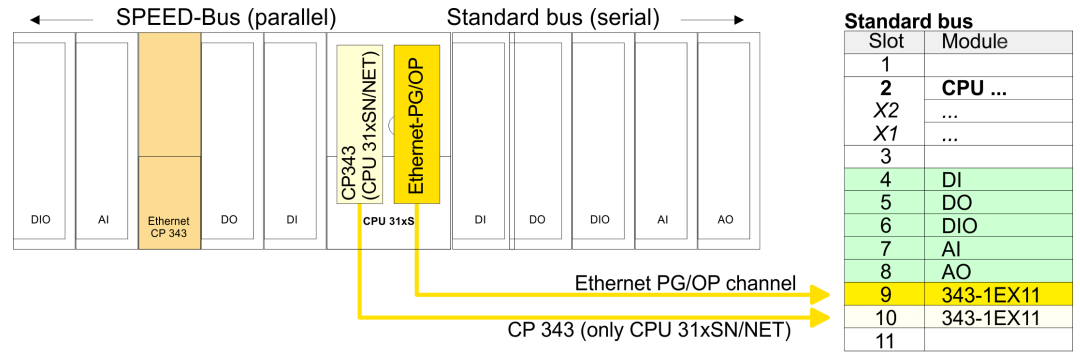

**Set IP parameters**

Open the property window via double-click on the CP 343-1EX11. Enter "General" and click at [Properties]. Type in the *IP address*, *subnet mask* and *gateway* for the CPs and select the wanted subnet.

**Project engineering and connecting CP 343S-NET - SPEED-Bus at the standard bus**

Due to the fact that a Ethernet CP 343-1EX71 - SPEED-Bus is in project engineering and parameterization similar to the CP 343-1 from Siemens, every Ethernet CP 343-1EX71 - SPEED-Bus is inserted at the standard bus as CP 343-1 (343-1EX11) after the already configured modules. The sequence follows the one at the SPEED-Bus from the right to the left. Connect the CP 343-1 to the required Ethernet network by means of Siemens NetPro and assign it with valid IP parameters.

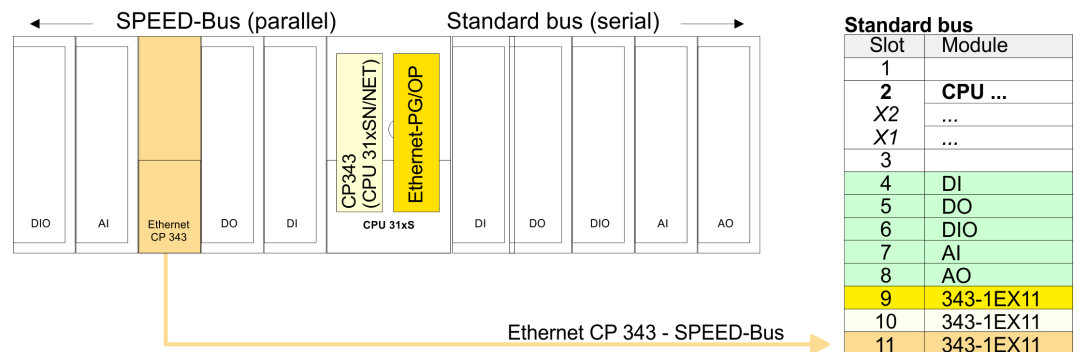

**Bus extension with IM 360 and IM 361**

Since as many as 32 modules can be addressed by the SPEED7 CPU in one row, but only 8 modules are supported by the Siemens SIMATIC manager, the IM 360 of the hardware catalog can be used as a virtual bus extension during project engineering. Here 3 further extension racks can be virtually connected via the IM 361. Bus extensions are always placed at slot 3.

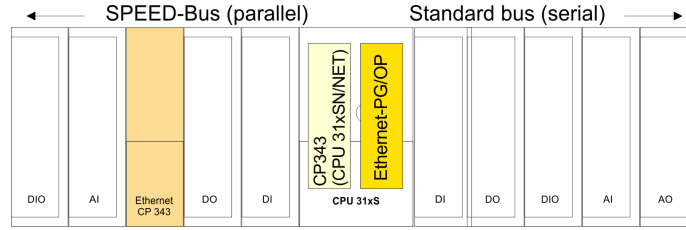

Slot	Module
1	
2	CPU ...
X2	...
X1	...
3	IM 360
4	DI
5	DO
6	DIO
7	AI
8	AO
9	343-1EX11
10	343-1EX11
11	343-1EX11

Slot	Module
1	
2	
3	IM 361
4	
5	
6	
7	
8	
9	
10	
11	

**Project engineering each SPEED-Bus module in a virtual master system**

1. The slot assignment of the SPEED-Bus modules and the parameterization of the in-/output periphery happens via a virtual PROFIBUS DP master system. For this, place as last module a DP master (342-5DA02 V5.0) with master system.
2. For the employment of the System 300S modules at the SPEED-Bus the inclusion of the System 300S modules into the hardware catalog via the GSD-file SPEEDBUS.GSD is required. After the installation of the SPEEDBUS.GSD you may locate at *Profibus DP/Additional field devices/I/O/VIPA\_SPEEDBUS* the DP slave system VIPA\_SPEEDBUS.
3. Now include for the CPU and every module at the SPEED-Bus a slave system "VIPA\_SPEEDBUS". Set as PROFIBUS address the slot no. (100...116) of the module and place the according module from the hardware catalog of VIPA\_SPEEDBUS to slot 0 of the slave system.

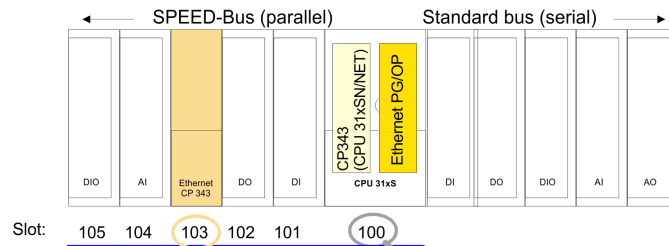

Slot	Module
1	
2	CPU ...
X2	...
X1	...
3	IM 360
4	DI
5	DO
6	DIO
7	AI
8	AO
9	343-1EX11
10	343-1EX11
11	343-1EX11

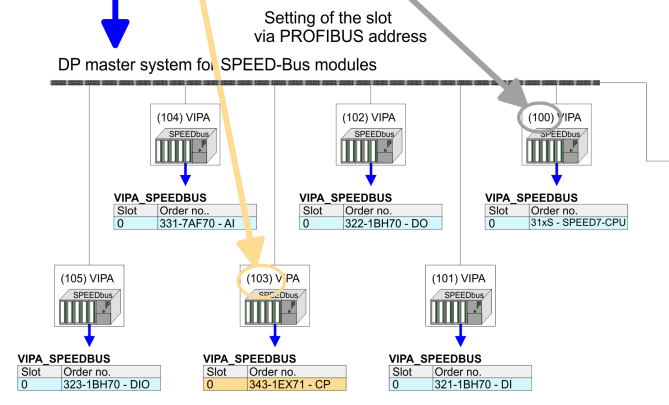

Slot	Module
1	
2	
3	IM 361
4	CP 342-5
5	
6	
7	
8	
9	
10	
11	

Ethernet-Network with Siemens NetPro

The according module is to be taken from the hardware catalog to slot 0 of VIPA\_SPEEDBUS.



Let with the CPs or DP master (also virtual SPEED-Bus master) at options the attitude "Save configuration data on the CPU" activated!

### Configure CPU via Ethernet with CP 343S-NET - SPEED-Bus

The following approach requires that the Ethernet CP 343S-NET - SPEED-Bus is available online, i.e. you assigned an IP address and subnet mask via a hardware configuration and the project engineering PC is in the same IP number circle. For more information see "Access to the Ethernet PG/OP channel and website..." above.

1. → Adjust the following setting in the SIMATIC manager at '*Options → PG/PC interface*': TCP/IP -> Network card...Protocol RFC 1006.
2. → Change to your project in the hardware configurator and start the transfer with '*PLC → Download to module*'.
3. → Select the favoured CP 343-1 and type as "address" the configured IP address. Before the transfer takes place you receive an error message that the "Online module" is different from the "Offline module". Ignore this message and start the transfer with [OK].
  - ➔ Now you may access the Ethernet CP 343S-NET - SPEED-Bus via your project and configure the favoured connections for the CP 343-1 with NetPro. Provided that no new hardware configuration is transferred to the CPU, the given CP 343-1 is permanently stored in the project as transfer channel.

## 5.10 Configure connections

### 5.10.1 Overview

The project engineering of connections i.e. the "link-up" between stations happens in NetPro from Siemens. NetPro is a graphical user interface for the link-up of stations. A communication connection enables the program controlled communication between two participants at the Industrial Ethernet. The communication partners may here be part of the same project or - at multi projects - separated within related part projects. Communication connections to partners outside of a project are configured via the object "In unknown project" or via deputy objects like "Other stations" or Siemens "SIMATIC S5 Station". The communication is controlled by the user program with Yaskawa handling blocks. To use this blocks, configured communication connections are always necessary in the active station.

### Properties communication connection

The following properties are characterizing a communication connection:

- One station always executes an active connection establishment.
- Bi-directional data transfer (Send and receive on one connection)
- Both participant have equal rights, i.e. every participant may initialize the send res. receive process event controlled.
- Except of the UDP connection, at a communication connection the address of the communication partner is set via the project engineering. Here the connection is active established by one station.

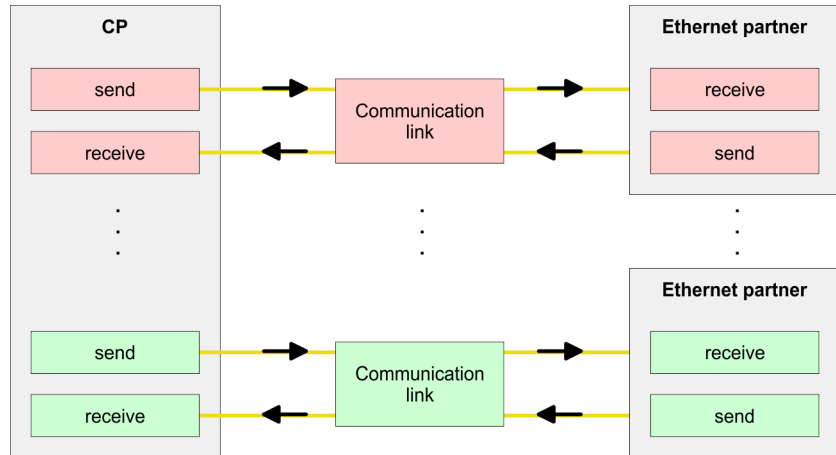

### Requirements

- Siemens SIMATIC Manager V 5.3 SP3 or higher and SIMATIC NET are installed.
- With the hardware configuration the CP was assigned with IP address data by the properties.



*Every station outside of the recent project must be configured as replacement objects like e.g. Siemens "SIMATIC S5" or "other station" or with the object "In unknown project". When creating a connection you may also choose the partner type "unspecified" and set the required remote parameter directly in the connection dialog.*

### 5.10.2 Siemens NetPro

#### Work environment of NetPro

For the project engineering of connections, a thorough knowledge with NetPro from Siemens is required! The following passage only describes the basic usage of NetPro. More detailed information about NetPro is to be found in the according online manual res. documentation. Start NetPro by clicking on a "net" in the Siemens SIMATIC Manager or on "connections" within the CPU.

The environment of NetPro has the following structure:

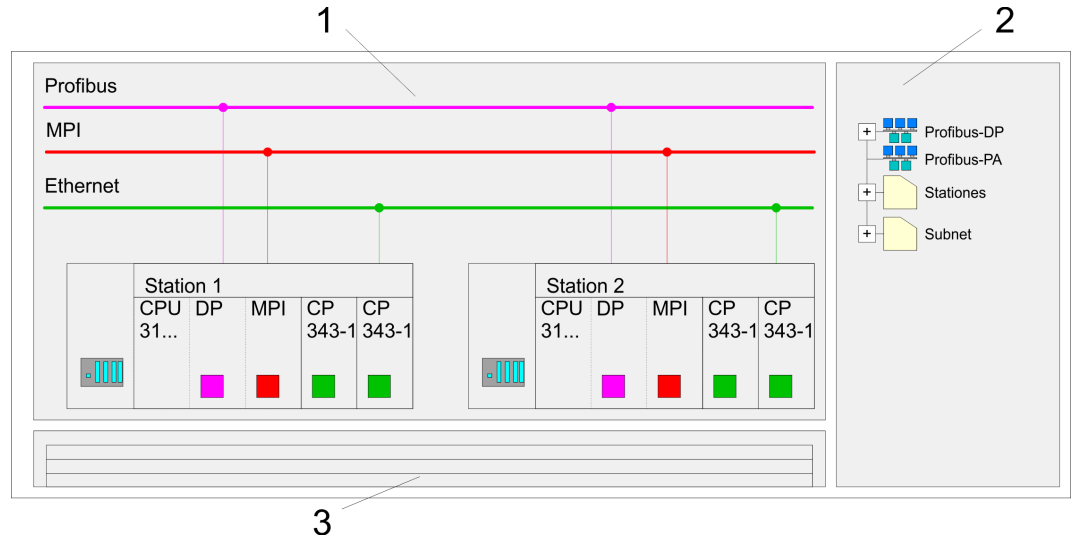

- 1 **Graphic net view:** All stations and networks are displayed in a graphic view. By clicking on the according component you may access and alter the concerning properties.
- 2 **Net objects:** This area displays all available net objects in a directory view. By dragging a wanted object to the net view you may include further net objects and open them in the hardware configurator.
- 3 **Connection table:** The connection table lists all connections in a table. This list is only shown when you highlighted a connectable module like e.g. a CPU. You may insert new connections into this table with the according command.

#### PLC stations

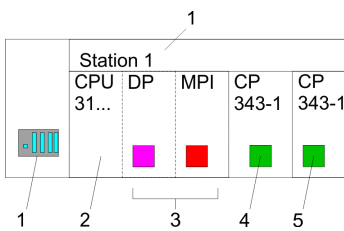

You receive the following graphical display for every PLC station and their component. By selecting the single components, the context menu offers you several functions:

- 1 **Station:** This includes a PLC station with rack, CPU and communication components. Via the context menu you may configure a station added from the net objects and its concerning components in the hardware configurator. After returning to NetPro, the new configured components are shown.
- 2 **CPU:** A click onto the CPU shows the connection table. The connection table shows all connections that are configured for the CPU.
- 3 **Internal communication components:** This shows the communication components that are available in your CPU. For the NET-CPU is configured as Siemens CPU, the internal components do not show the CP. Due to this, the internal CPs of the NET-CPU must be configured as external CPs behind the really plugged modules. The CPs are then also shown in NetPro as external CPs (4, 5) in the station.
- 4 **Ethernet PG/OP channel:** The internal Ethernet PG/OP channel must always be configured as external CP in the hardware configuration. This CP only serves the PG/OP communication. Configurable connections are not possible.
- 5 **The internal CP 343 must always be configured as external 2. CP in the hardware configuration after the Ethernet PG/OP channel.**

## Link up stations

NetPro offers you the option to link-up the communicating stations. You may link-up the stations via the properties in the hardware configuration or graphically via NetPro. For this you point the mouse on the coloured net mark of the according CP and drag and drop it to the net you want to link. Now the CP is linked up to the wanted net by means of a line.

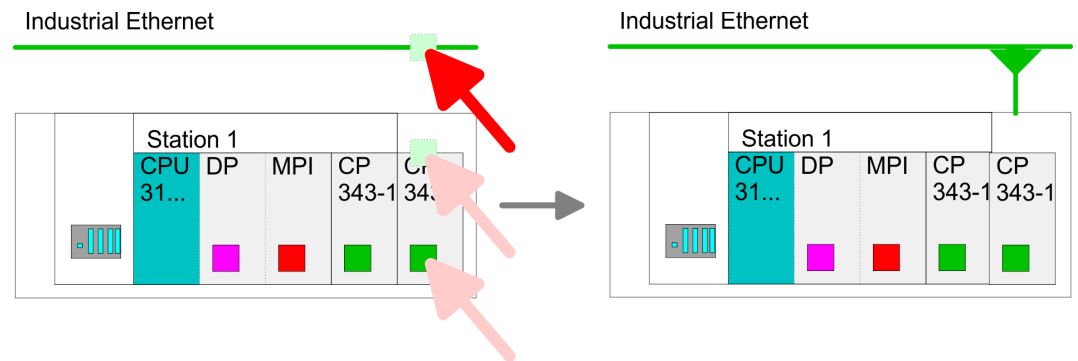

## Projecting connections

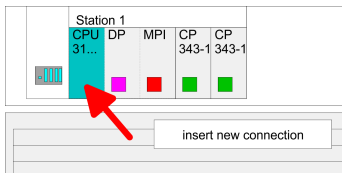

1. → For the project engineering of connections, open the connection list by selecting the according CPU. Open 'Context menu → Insert new connection':

- Connection partner (partner station)
  - A dialog window opens where you may choose the *connection partner* and the *Connection type*.
- Specified connection partner
  - Each station configured in the Siemens SIMATIC manager is listed in the table of connection partner.
  - These stations are unique *specified* by an IP address and a subnet mask.
- Unspecified connection partner
  - Here the connection partner may exist in the current project or in an unknown project.
  - Connection jobs to an unknown project must be defined by an unique connection name, which is to be used in the projects of both stations.
  - Due to this allocation the connection remains *unspecified*.
- All broadcast stations
  - Exclusive at UDP connections you may send to every reachable participant.
  - The receipt of user data is not possible.
  - The broadcast participants are specified by one port and one broadcast address at sender and receiver.
  - Per default, broadcasts that are only serving the Ethernet communication, like e.g. ARP-Requests (Search MAC <> IP address), are received and accordingly processed.
  - For the identification of the broadcast participants within the net, you have to define a valid broadcast address as partner IP during project engineering of a broadcast connection.
  - Additionally to the broadcast address you have to set a common port for sender and receiver.
- All multicast stations
  - By selecting 'All Multicast stations' you define that UDP telegrams have to be sent respectively received by all participants of a multicast group.
  - In contrast to broadcast here a reception is possible.
  - For the identification of the multicast participants within the net, you have to define one valid multicast group address and one port for sender and receiver. The maximum number of multicast circles, which are supported by the CP, is identical to the maximum number of connections.

- Connection types

The following connection types are available for communication:

- *Siemens S7 connections, Send/Receive connections* (TCP, ISO-on-TCP and ISO transport) for secured data transfer of data blocks between two Ethernet stations.
- *UDP* for not secured data transfer of data blocks between two Ethernet stations.

**2.** → Select the connection partner and the type of connection and confirm with [OK].

- ➔ If activated, a properties dialog for the according connection opens as link to your PLC user program.

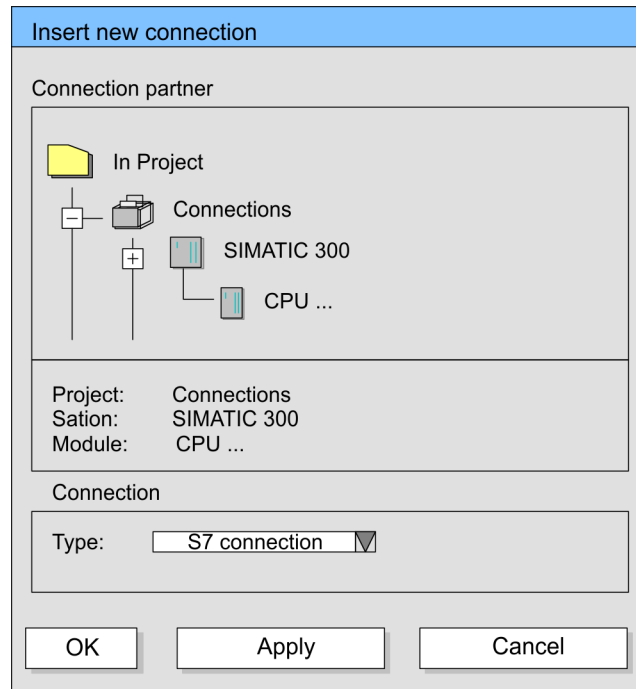

**3.** → After every connection was configured by this way, you may "save and compile" your project and exit NetPro.



*To store the CP project engineering data in the system data, you have to activate the option "Store project data in the CPU" (default setting) at object properties area Options in the hardware configuration of the CP.*

### 5.10.3 Connection type - S7

#### Siemens S7 connection

- For data transfer with Siemens S7 connections the product specific FB/SFB handling blocks are necessary; the deployment is described in the manual "Operation list" of your CPU.
- At Siemens S7 connections the communication connections are specified by a connection ID for each communication partner.
- A connection is specified by the local and partner connection end point.
- At Siemens S7 connections the TSAPs must be congruent crosswise. The following parameters define a connection end point:

The following parameters define a connection end point:

Station A				Station B
remote TSAP	→	Siemens	→	local TSAP
local TSAP	←	S7 connection	←	remote TSAP
ID A				ID B

#### Combination options with deployment of the product specific FB/SFB handling blocks

Connection partner	Connection establishing	Connection
specified in NetPro (in the current project)	active/passive	specified
unspecified in NetPro (in the current project)	active	specified
	passive	unspecified
unspecified in NetPro (in the unknown project)	active/passive	specified (connection name in an other project)

In the following every relevant parameter of a Siemens S7 connection is described:

- **Local connection end point:**  
Here you may define how the connection is to be established. Since the Siemens SIMATIC Manager can identify the communication options by means of the end points, some options are already preset and may not be changed.
  - **Establish an active connection:**  
An established connection is precondition for data transfer. By activating the option Establish an active connection the local station establishes the connection. Please regard not every station is able to establish a connection. Here the job is to be made by the partner station.
  - **One-way:**  
If activated only one-way communication blocks like PUT and GET may be used for communication in the user program. Here the partner station acts as server, which neither may send active nor receive active.
- **Block parameters:**
  - **Local ID:**  
The ID is the link to your PLC program. The ID must be identical to the ID of the call interface of the product specific FB/SFB handling block.
  - **[Default]:**  
As soon as you click at [Default], the ID is reset to system generated ID.

- **Connection path:**  
In this part of the dialog window the connection path between the local and the partner station may be set. Depending on the linking of the modules the possible interfaces for communication are listed in a selection field.
  - **[Address details]:**  
With this button a dialog window is opened, which shows address information about the local and partner station. The parameters may also be changed.
  - **TSAP:**  
With Siemens S7 connections a TSAP is automatically generated of the connection resource (one-way/two-way) and state of place (rack/slot respectively system internal ID at PC stations).
  - **Connection resource:**  
The connection resource is part of the TSAP of the local station respectively of the partner. Not every connection resource may be used for every connection type. Depending on the connection partner and the connection type the range of values is limited respectively the connection resource is fix specified.

### Siemens S7 connection - Communication functions

With the SPEED7 CPUs there are two possibilities for the deployment of the communication functions:

- **Siemens S7-300 communication functions:**  
By integration of the product specific function blocks FB 12 ... FB 15 you may access the Siemens S7-300 communication functions.
- **Siemens S7-400 communication functions:**  
For the Siemens S7-400 communication functions the SFB 12 ... SFB 15 are to be used, which were integrated to the operating system of the CPU. Here copy the interface description of the SFBs from the standard library at system function block to the directory container, generate an instance data block for each call and call the SFB with the associated instance data block.

### Function blocks

FB/SFB	Label	Description
FB/SFB 12	BSEND	<p>Sending data in blocks:</p> <p>FB/SFB 12 BSEND sends data to a remote partner FB/SFB of the type BRCV (FB/SFB 13). The data area to be transmitted is segmented. Each segment is sent individually to the partner. The last segment is acknowledged by the partner as it is received, independently of the calling up of the corresponding FB/SFB/BRCV. With this type of data transfer, more data can be transported between the communications partners than is possible with all other communication FBs/SFBs for configured S7 connections, namely 65534bytes.</p>
FB/SFB 13	BRCV	<p>Receiving data in blocks:</p> <p>The FB/SFB 13 BRCV can receive data from a remote partner FB/SFB of the type BSEND (FB/SFB 12). The parameter R_ID of both FB/SFBs must be identical. After each received data segment an acknowledgement is sent to the partner FB/SFB and the LEN parameter is updated.</p>
FB/SFB 14	GET	<p>Remote CPU read:</p> <p>The FB/SFB 14 GET can be used to read data from a remote CPU. The respective CPU must be in RUN mode or in STOP mode.</p>
FB/SFB 15	PUT	<p>Remote CPU write:</p> <p>The FB/SFB 15 PUT can be used to write data to a remote CPU. The respective CPU may be in RUN mode or in STOP mode.</p>

## 5.10.4 Connection type - Send/Receive

### Send/Receive connections

At the PLC side for data transfer with these connections the product specific handling blocks AG\_SEND (FC 5) and AG\_RECV (FC 6) are to be used.

Send/receive connections are the following connections:

- TCP (SEND-RECEIVE, FETCH-WRITE PASSIVE)
- ISO-on-TCP (SEND-RECEIVE, FETCH-WRITE PASSIVE)
- ISO-on-TCP (SEND-RECEIVE, FETCH-WRITE PASSIVE)
- UDP (SEND-RECEIVE)

The following parameters define a connection end point:

Station A				Station B	
remote port:	→	TCP	→	local port	
local port	←	connection	←	remote port	
IP address A				IP address B	

Station A				Station B	
remote TSAP	→	ISO TCP	→	local TSAP	
local TSAP	←	connection	←	remote TSAP	
IP address A				IP address B	

Station A				Station B	
remote TSAP	→	ISO transport	→	local TSAP	
local TSAP	←	connection	←	remote TSAP	
MAC address A				MAC address B	

Station A				Station B	
remote port	→	UDP	→	local port	
local port	←	connection	←	remote port	
IP address A				IP address B	

### Combination options with the different operating modes

Connection partner	Connection type	Connection establishment	Connection	Operating mode
specified in NetPro (in current project)	TCP / ISO-on-TCP / ISO-Transport	active/passive	specified	SEND/RECEIVE
	UDP	-		
unspecified in NetPro (in current project)	TCP / ISO-on-TCP / ISO-Transport	active	specified	SEND/RECEIVE
		passive	part specified (Port/TSAP)	SEND/RECEIVE FETCH PASSIVE
	UDP	-	unspecified	WRITE PASSIVE
unspecified in NetPro (in unknown project)	TCP / ISO-on-TCP / ISO-Transport	active	specified	SEND/RECEIVE
		passive	(connection name in an other project)	SEND/RECEIVE FETCH PASSIVE WRITE PASSIVE
	UDP	-		SEND/RECEIVE
All broadcast stations	UDP	-	specified (Port, Broadcast addr.)	SEND
All multicast stations	UDP	-	specified (Port, Multicast group)	SEND/RECEIVE

In the following each relevant parameters of the different connection types are described:

- **General**

In this tab the general connection parameters are listed, which identify the local connection end point.

- *ID*

This entry is identical to the entry of the connection table. The value may always be changed. Please also regard to adjust the ID parameter of the call interface of the FC.

- *Name*

This field contains the name of the connection. The name is generated by the system and may be changed on every time.

- *Via CP [Route]*

Here is the CP listed, which should be used for connection. With the button [Route] the appropriate CP may be selected for communication. Do not select the 1. CP of the route for communication connections. The 1. CP is always the Ethernet PG/OP channel, which does not support configurable connections.

- *Active connection establishment*

If activated the connection to the partner is active established by the local station. Here the partner is to be specified in the tab 'Addresses'. At an unspecified connection the connection is passive established.

- **Block parameters**

- Here the parameters *ID* and *LADDR* for your user program are shown. Both are parameters, which are to be preset if you use the FC 5 and FC 6 (AG\_SEND, AG\_RECEIVE). Please always use the FCs, which you may receive from Yaskawa.

- **Addresses**

The Addresses tab displays the relevant local and remote address information as proposed values. Depending on the kind of communication the address information may remain unspecified.

- *Port*

Ports respectively port addresses are defining the access point to the user application within the station/CPU. These must be unique. A port address should be within the range of 2000...65535.

- *TSAP*

ISO-on-TCP and ISO transport support TSAP lengths (Transport Service Access Point) of 1...16byte. You may enter the TSAP in ASCII or hexadecimal format. The calculation of the length happens automatically.

- **Options**

Depending on the specification of the connecting partner the following *operating modes* may be set respectively displayed:

- SEND/RECEIVE

The SEND/RECEIVE interface allows the program-controlled communication to any partner station via a configured connection. Here the data transfer happens by a call from your user application. The FC5 and FC6 that are part of the controls library are serving as interface. This enables your PLC to send messages depending on process events.

- FETCH/WRITE PASSIVE

With the help of FETCH/WRITE services partner systems have the direct access to memory areas of the CPU. These are "passive" communication connections that have to be configured. The connections are "actively" established by the connection partner.

- FETCH PASSIVE (request data)  
FETCH allows a partner system to request data.
- WRITE PASSIVE (write data)  
This allows a partner system to write data in the data area of the CPU.

#### ■ Overview

Here every configured connections of this station and its partner are displayed. These data are information and may not be changed.



- *If a CP is exchanged by another one, this must at least provide the same services and must at least have the same version level. Only this can guarantee the connections configured via the CP to remain consistent and useable.*
- *By appropriate shift respectively delete activities in the Siemens SIMATIC manager connections may lose the allocation to the CP. These connections are marked with "!" at ID of the overview.*

### 5.10.4.1 FC 5 - AG\_SEND / FC 6 - AG\_RECV - CP 343 communication

#### Overview

The two blocks serve the processing of the Ethernet-CP 343 connection commands on the side of the PLC. Including these blocks in the cycle block OB1 you may send and receive data cyclically.

Within these blocks, the SFCs 205 and 206 are called that are stored as special function blocks in the CPU.



*Please regard that you may only use the SEND/RECV-FCs from Yaskawa in your user application for the communication with Yaskawa CPs. At a change to Yaskawa CPs in an already existing project, the present AG\_SEND / AG\_LSEND res. AG\_RECV / AG\_LRECV may be replaced by AG\_SEND res. AG\_RECV from Yaskawa without adjustment. Due to the fact that the CP automatically adjusts itself to the length of the data to transfer, the L variant of SEND res. RECV is not required for Yaskawa CPs.*

#### Communication blocks

For the communication between CPU and Ethernet-CP 343, the following FCs are available:

##### AG\_SEND (FC 5)

This block transfers the user data from the data area given in *SEND* to the CP specified via *ID* and *LADDR*. As data area you may set a PA, bit memory or data block area. When the data area has been transferred without errors, "order ready without error" is returned.

##### AG\_RECV (FC 6)

The block transfers the user data from the CP into a data area defined via *RECV*. As data area you may set a PA, bit memory or data block area. When the data area has been transferred without errors, "order ready without error" is returned.

#### Status displays

The CP processes send and receive commands independently from the CPU cycle and needs for this transfer time. The interface with the FC blocks to the user application is here synchronized by means of acknowledgements/receipts.

For status evaluation the communication blocks return parameters that may be evaluated directly in the user application.

These status displays are updated at every block call.

**Deployment at high communication load**

Do not use cyclic calls of the communication blocks in OB 1. This causes a permanent communication between CPU and CP. Program instead the communication blocks within a time OB where the cycle time is higher res. event controlled.

**FC call is faster than CP transfer time**

If a block is called a second time in the user application before the data of the last time is already completely send res. received, the FC block interface reacts like this:

**AG\_SEND**

No command is accepted until the data transfer has been acknowledged from the partner via the connection. Until this you receive the message "Order running" before the CP is able to receive a new command for this connection.

**AG\_RECV**

The order is acknowledged with the message "No data available yet" as long as the CP has not received the receive data completely.

**AG\_SEND, AG\_RECV in the user application**

The following illustration shows a possible sequence for the FC blocks together with the organizations and program blocks in the CPU cycle:

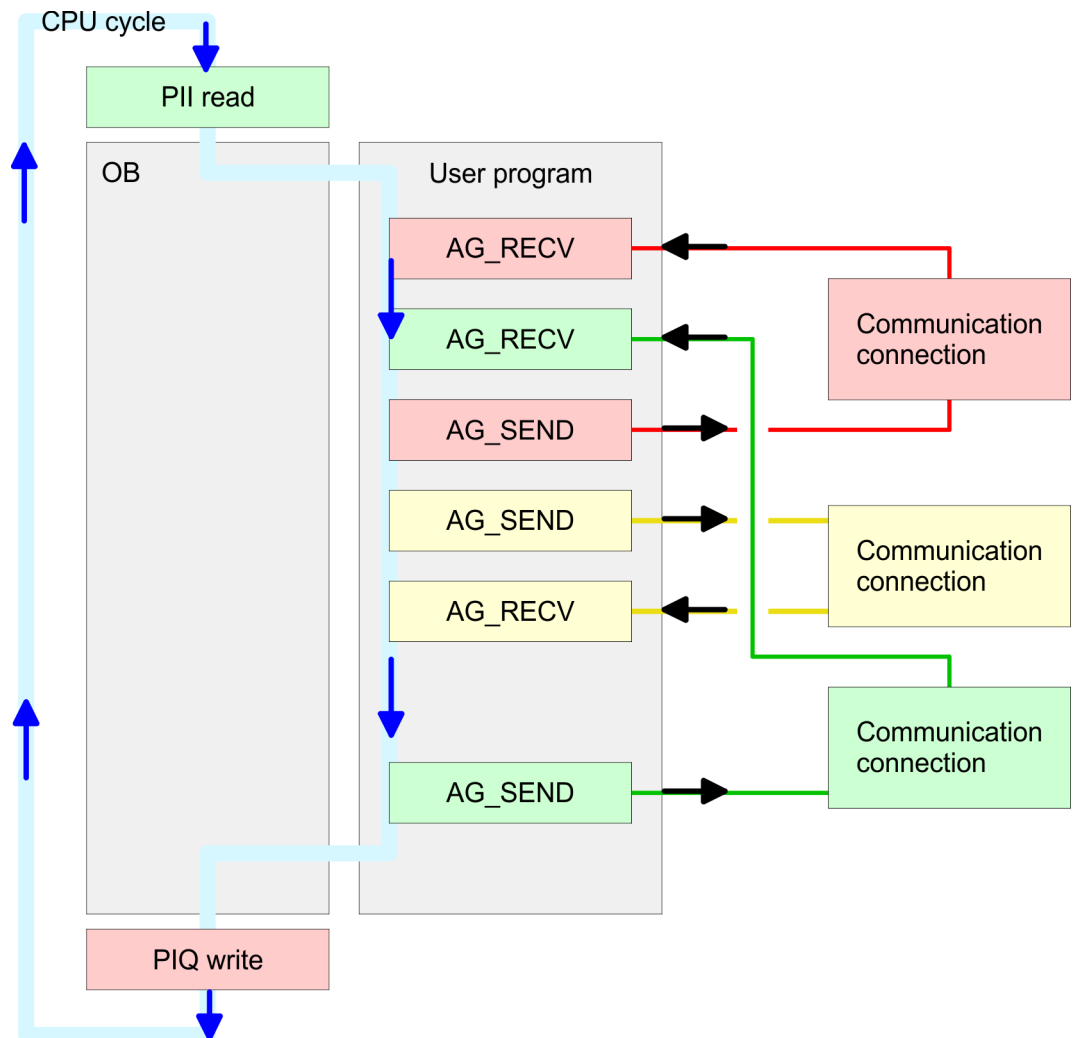

The FC blocks with concerning communication connection are summed up by colour. Here you may also see that your user application may consist of any number of blocks. This allows you to send or receive data (with AG\_SEND res. AG\_RECV) event or program driven at any wanted point within the CPU cycle. You may also call the blocks for **one** communication connection several times within one cycle.

**AG\_SEND (FC 5)**

By means of AG\_SEND the data to send are transferred from the CPU to an Ethernet CP 343.

**Parameters**

Parameter	Declaration	Data type	Description
ACT	INPUT	BOOL	Activation of the sender 0: Updates <i>DONE</i> , <i>ERROR</i> and <i>STATUS</i> 1: The data area defined in <i>SEND</i> with the length <i>LEN</i> is send
ID	INPUT	INT	Connection number 1 ... 16 (identical with <i>ID</i> of NetPro)
LADDR	INPUT	WORD	Logical basic address of the CP (identical with <i>LADDR</i> of NetPro)
SEND	INPUT	ANY	Data area
LEN	INPUT	INT	Number of bytes from data area to transfer
DONE	OUTPUT	BOOL	Status parameter for the order 0: Order running 1: Order ready without error
ERROR	OUTPUT	BOOL	Error message 0: Order running (at <i>DONE</i> = 0) 0: Order ready without error (at <i>DONE</i> = 1) 1: Order ready with error
STATUS	OUTPUT	WORD	Status message returned with <i>DONE</i> and <i>ERROR</i> . More details are to be found in the following table.

**AG\_RECV (FC 6)**

With the 1. call of AG\_RECV a receive buffer for the communication between CPU and an Ethernet CP 343 is established. From now on received data are automatically stored in this buffer. As soon as after calling AG\_RECV the return value of *NDR* = 1 is returned, valid data are present.

Since with a further call of AG\_RECV the receive buffer is established again for the receipt of new data, you have to save the previous received data.

**Parameters**

Parameter	Declaration	Data type	Description
ID	INPUT	INT	Connection number 1 ... 16 (identical with <i>ID</i> of NetPro)
LADDR	INPUT	WORD	Logical basic address of the CP (identical with <i>LADDR</i> of NetPro)
RECV	INPUT	ANY	Data area for the received data.
NDR	OUTPUT	BOOL	Status parameter for the order 0: Order running 1: Order ready data received without error
ERROR	OUTPUT	BOOL	Error message 0: Order running (at <i>NDR</i> = 0) 0: Order ready without error (at <i>NDR</i> = 1) 1: Order ready with error

Configure connections &gt; Connection type - Send/Receive

Parameter	Declaration	Data type	Description
STATUS	OUTPUT	WORD	Status message returned with <i>NDR</i> and <i>ERROR</i> . More details are to be found in the following table.
LEN	OUTPUT	INT	Number of bytes that have been received

**DONE, ERROR, STATUS**

The following table shows all messages that can be returned by the Ethernet CP 343 after a SEND res. RECV command.

A "-" means that this message is not available for the concerning SEND res. RECV command.

DONE (SEND)	NDR (RECV)	ERROR	STATUS	Description
1	-	0	0000h	Order ready without error.
-	1	0	0000h	New data received without error.
0	-	0	0000h	No order present.
-	0	0	8180h	No data available yet.
0	0	0	8181h	Order running
0	0	1	8183h	No CP project engineering for this order.
0	-	1	8184h	System error
-	0	1	8184h	System error (destination data area failure).
0	-	1	8185h	Parameter <i>LEN</i> exceeds source area <i>SEND</i> .
	0	1	8185h	Destination buffer (RECV) too small.
0	0	1	8186h	Parameter <i>ID</i> invalid (not within 1 ... 16).
0	-	1	8302h	No receive resources at destination station, receive station is not able to process received data fast enough res. has no receive resources reserved.
0	-	1	8304h	The connection is not established. The send command shouldn't be sent again before a delay time of > 100ms.
-	0	1	8304h	The connection is not established. The receive command shouldn't be sent again after a delay time of > 100ms.
0	-	1	8311h	Destination station not available under the defined Ethernet address.
0	-	1	8312h	Ethernet error in the CP.
0		1	8F22h	Source area invalid, e.g. when area in DB not present Parameter <i>LEN</i> < 0
-	0	1	8F23h	Source area invalid, e.g. when area in DB not present Parameter <i>LEN</i> < 0
0	-	1	8F24h	Range error at reading a parameter.
-	0	1	8F25h	Range error at writing a parameter.
0	-	1	8F28h	Orientation error at reading a parameter.
-	0	1	8F29h	Orientation error at writing a parameter.
-	0	1	8F30h	Parameter is within write protected 1. recent data block
-	0	1	8F31h	Parameter is within write protected 2. recent data block
0	0	1	8F32h	Parameter contains oversized DB number.
0	0	1	8F33h	DB number error
0	0	1	8F3Ah	Area not loaded (DB)
0	-	1	8F42h	Acknowledgment delay at reading a parameter from peripheral area.
-	0	1	8F43h	Acknowledgment delay at writing a parameter from peripheral area.

DONE (SEND)	NDR (RECV)	ERROR	STATUS	Description
0	-	1	8F44h	Address of the parameter to read locked in access track
-	0	1	8F45h	Address of the parameter to write locked in access track
0	0	1	8F7Fh	Internal error e.g. invalid ANY reference e.g. parameter <i>LEN</i> = 0.
0	0	1	8090h	Module with this module start address not present or CPU in STOP.
0	0	1	8091h	Module start address not within double word grid.
0	0	1	8092h	reference contains type setting unequal BYTE.
-	0	1	80A0h	Negative acknowledgment at reading the module.
0	0	1	80A4h	reserved
0	0	1	80B0h	Module doesn't recognize record set.
0	0	1	80B1h	The length setting (in parameter <i>LEN</i> ) is invalid.
0	0	1	80B2h	reserved
0	0	1	80C0h	Record set not readable.
0	0	1	80C1h	The set record set is still in process.
0	0	1	80C2h	Order accumulation.
0	0	1	80C3h	The operating sources (memory) of the CPU are temporarily occupied.
0	0	1	80C4h	Communication error (occurs temporarily; a repetition in the user application is reasonable).
0	0	1	80D2h	Module start address is wrong.

**Status parameter at reboot**

At a reboot of the CP, the output parameters are set as follows:

- DONE = 0
- NDR = 0
- ERROR = 0
- STATUS = 8180h (at AG\_RECV)
- STATUS = 8181h (at AG\_SEND)

### 5.11 NCM diagnostic - Help for error diagnostic

**NCM diagnostics - Help for error diagnostics**

This page shall help you with the error diagnostics. The following check list shows a number of typical problems and their probable causes:

Question	Remedy with "no"
CPU in RUN?	<ul style="list-style-type: none"> <li>■ Check DC 24V power supply.</li> <li>■ Set the operating mode switch to position RUN.</li> <li>■ Check PLC program and transfer it again.</li> </ul>
AG_SEND, AG_RECV in user application?	These 2 blocks are required in the user application for the data transfer between CP and CPU. Both blocks must also be called with a passive connection.
Is CP able to connect?	<ul style="list-style-type: none"> <li>■ Check Ethernet cable (at a point-to-point connection a crossed Ethernet cable is to be used).</li> <li>■ Check IP address.</li> </ul>
Can data be transferred?	<ul style="list-style-type: none"> <li>■ Check Port no. for read and write.</li> <li>■ Check source and destination areas.</li> <li>■ Check if the 2. CP is selected in the route.</li> <li>■ Enlarge the receive respectively send buffer defined via the ANY pointer.</li> </ul>
Is the complete data block sent at ISO-on-TCP?	<ul style="list-style-type: none"> <li>■ Check the LEN parameter at AG_SEND.</li> <li>■ Set the receive respectively send buffer defined via the ANY pointer to the required size.</li> </ul>

**Siemens NCM S7 diagnostic**

The CP supports the Siemens NCM diagnostic tool. The NCM diagnostic tool is part of the Siemens SIMATIC manager. This tool delivers information about the operating state of the communication functions of the online CPs dynamically.

The following diagnostic functions are available:

- Check operating state at Ethernet
- Read the diagnostic buffer of the CP
- Diagnostics of connections

**Start NCM diagnostic**

The diagnostic tool is started by *'Windows-START menu → SIMATIC → ... NCM S7 → Diagnostic'*.

**Structure**

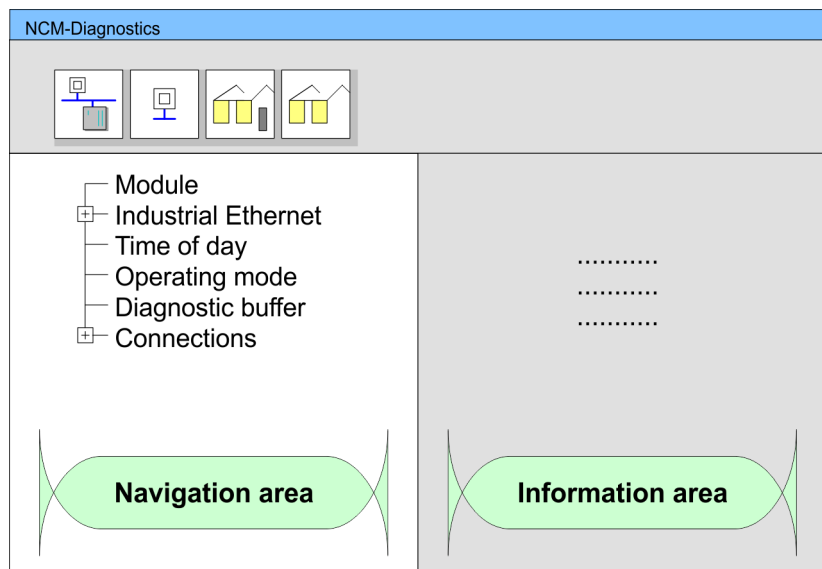

The working surface of the diagnostic tool has the following structure:

- The *'navigation area'* at the left side contains the hierarchical listed diagnostic objects. Depending on CP type and configured connections there is an adjusted object structure in the navigation area.
- The *'information area'* at the right side always shows the result of the navigation function you chose in the navigation area.

### No diagnostic without connection

A diagnostic always requires an online connection to the CP you want to control. For this click at  the symbol bar.

The following dialog window appears:

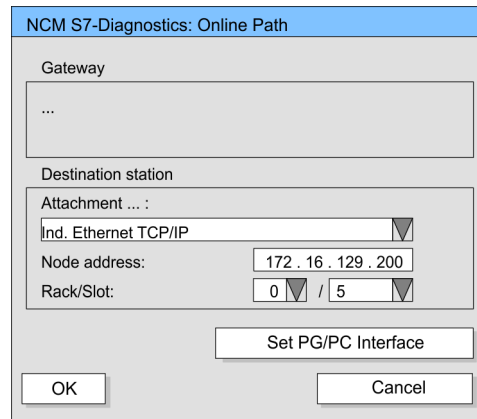

Set the following parameters at *'Destination station'*:

- *Attachment ...:*  
Ind. Ethernet TCP/IP
- *Node addr.:*  
Enter the IP address of the CP
- *Rack/slot:*  
Enter the module rack and slot of the CP 343 that you've placed at the 2. slot. Set your PG/PC interface to "TCP/IP -> Network card .... ". Via [OK] you start the online diagnostic.

### Read diagnostic buffer

The CP has a diagnostic buffer. This has the architecture of a ring memory and may store up to 100 diagnostic messages. The NCM diagnostic allows you to monitor and evaluate the diagnostic messages via the diagnostic object *Diagnostic buffer*. Via a double click on a diagnostic message the NCM diagnostic shows further information.

### Approach for diagnostic

You execute a diagnostic by clicking on a diagnostic object in the navigation area. More functions are available via the menu and the symbol bar.



Please always control the preconditions for an operative communication using the check list. → ['NCM diagnostics - Help for error diagnostics'...page 60](#)

For the aimed diagnostic deployment the following approach is convenient:

1. ➤ Start diagnostic.
2. ➤ Open the dialog for the online connection with , enter connection parameters and establish the online connection with [OK].
3. ➤ Identify the CP and check the recent state of the CP via module status.

4. → Check the connections for particularities like:
  - Connection status
  - Receive status
  - Send status
5. → Control and evaluate the diagnostic buffer of the CP via 'Diagnostic buffer'.
6. → As needed, alter project engineering respectively programming and restart diagnostic.

## 5.12 Coupling to other systems

### Overview

The operating mode FETCH/WRITE supported at TCP res. ISO-on-TCP can be used for accesses of partner devices to the PLC system memory. To be able to use this access also for example for implementation in PC applications you have to know the telegram structure for orders. The specific headers for request and acknowledgement telegrams have per default a length of 16Byte and are described at the following pages.

### ORG format

The organization format is the abbreviated description of a data source or a data destination in a PLC environment. The available ORG formats are listed in the following table. The ERW-identifier is used for the addressing of data blocks. In this case the data block number is entered into this identifier. The start address and quantity provide the address for the memory area and they are stored in HIGH-/LOW- format (Motorola-formatted addresses)

Description	Type	Range
ORG identifier	BYTE	1...x
ERW identifier	BYTE	1...255
Start address	HILOWORD	0...y
Length	HILOWORD	1...z

The following table contains a list of available ORG-formats. The "length" must not be entered as -1 (FFFFh).

#### ORG identifier 01h-04h

CPU area	DB	MB	EB	AB
ORG identifier	01h	02h	03h	04h
Description	Source/destination data from/into data Block in main memory.	Source/destination data from/into flag memory area	Source/destination data from/into process image of the inputs (PII).	Source/destination data from/into process image of the outputs (PIQ).
ERW identifier (DBNO)	DB, from where the source data is retrieved or to where the destination data is transferred.	irrelevant	irrelevant	irrelevant
Start address significance	DBB-No., from where the data is retrieved or where the data is saved.	MB-No., from where the data is retrieved or where the data is saved.	IB-No., from where the data is retrieved or where the data is saved.	QB-No., from where the data is retrieved or where the data is saved.
Length significance	Length of the source/destination data block in words.	Length of the source/destination data block in bytes	Length of the source/destination data block in bytes	Length of the source/destination data block in bytes

#### ORG identifier 05h-07h

CPU area	PB	ZB	TB
ORG identifier	05h	06h	07h

CPU area	PB	ZB	TB
Description	source/destination data from/into peripheral modules. Input module for source data, output module for destination data.	source/destination data from/into counter cells.	Source/destination data from/into timer cells.
ERW identifier (DBNO)	irrelevant	irrelevant	irrelevant
Start address Significance	PB-No., from where the data can be retrieved or where it is saved.	ZB-No., from where the data can be retrieved or where it is saved.	TB-No., from where the data can be retrieved or where it is saved.
Length Significance	Length of the source/destination data block in bytes.	Length of the source/destination data block in words (counter cell = 1 word).	Length of the source/destination data block in words (counter cell = 1 word).

### Transfer of blocks with numbers >255

#### ORG identifier 81h-FFh

To transfer data blocks of the number range 256 ... 32768 you may use the ORG identifier 81h-FFh. For the setting of a DB No. >255 needs a length of one word, the DBNO<sub>new</sub> is assembled from the content of the ORG identifier and the DBNO. DBNO<sub>new</sub> is created as word as follows:

#### DBNO<sub>new</sub>

High-Byte								Low-Byte							
1	x	x	x	x	x	x	x	x	x	x	x	x	x	x	x
ORG identifier (0XXXXXXXX)								DBNR (XXXXXXXXX)							

If the highest bit of the ORG identifier is set, the Low-Byte of DBNO<sub>new</sub> is defined via DBNO and the High-Byte of DBNO<sub>new</sub> via ORG identifier, where the highest bit of the ORG identifier is eliminated. The following formula illustrates this:

$$\text{DBNO}_{\text{new}} = 256 \times (\text{ORG-identifier AND } 7\text{Fh}) + \text{DBNO}$$

### Structure of PLC-Header

For every FETCH and WRITE the CP generates PLC header for request and acknowledgment messages. Normally the length of these headers is 16Bytes and have the following structure:

#### WRITE

Request telegram Remote Station	Acknowledgement telegram CP
System ID = "S5" (Word)	System ID = "S5" (Word)
Length Header = 10h (Byte)	Length Header = 10h (Byte)
ID OP-Code = 01h (Byte)	ID OP-Code = 01h (Byte)
Length OP-Code = 03h (Byte)	Length OP-Code = 03h (Byte)
<b>OP-Code = 03h (Byte)</b>	<b>OP-Code = 04h (Byte)</b>
ORG block = 03h (Byte)	Ackn. block = 0Fh (Byte)
Length ORG block = 08h (Byte)	Length Ack. block = 03h (Byte)
ORG identifier <sup>1</sup> (Byte)	Error no. (Byte)
ERW identifier (Byte)	Empty block = FFh (Byte)
Start address (Word)	Length empty block = 07h (Byte)
Length (Word)	5 empty bytes attached
Empty block = FFh (Byte)	
Length empty block = 02h (Byte)	
Data up to 64kByte (only if error no.=0)	

Coupling to other systems

**FETCH**

<b>Request telegram Remote Station</b>	<b>Acknowledgement telegram CP</b>
System ID = "S5" (Word)	System ID = "S5" (Word)
Length Header = 10h (Byte)	Length Header = 10h (Byte)
ID OP-Code = 01h (Byte)	ID OP-Code = 01h (Byte)
Length OP-Code = 03h (Byte)	Length OP-Code = 03h (Byte)
<b>OP-Code = 05h (Byte)</b>	<b>OP-Code = 06h (Byte)</b>
ORG block = 03h (Byte)	Ackn. block = 0Fh (Byte)
Length ORG block = 08h (Byte)	Length Ack. block = 03h (Byte)
ORG identifier <sup>1</sup> (Byte)	Error no. (Byte)
ERW identifier (Byte)	Empty block = FFh (Byte)
Start address (Word)	Length empty block = 07h (Byte)
Length (Word)	5 empty bytes attached
Empty block = FFh (Byte)	Data up to 64kByte
Length empty block = 02h (Byte)	(only if error no.=0)

1) More details to the data area is to be found at "ORG-Format" above.



*Please regard that in opposite to Siemens-S5 systems, the block addressing of these CPUs takes the start address as byte number and the length as number of words.*

**Messages of error no.**

The following messages can be returned via *error no.*:

<b>Error no.</b>	<b>Message</b>
00h	No error occurred
01h	The defined area cannot be read res. written